

26-2900 Series

Regulators - Relief / Backpressure

D26291387X012

Specifications

For other materials or modifications, please consult TESCOM.

OPERATING PARAMETERS

Pressure rating per criteria of ANSI/ASME B31.3

Maximum Control Pressure

1000 psig / 69.0 bar

Maximum Reference Ranges

1000 psig / 69.0 bar

Bias Pressure Ranges

0, 0-15, 0-30, 0-45 psig / 0, 0-1.0, 0-2.1, 0-3.1 bar

Design Proof Pressure

150% maximum rated

Leakage

Bubble-tight

Operating Temperature

0°F to 165°F / -18°C to 74°C

Flow Capacity

$C_v = 2.0$

Crack-to-Reseat Differential

0-15 psig / 0-1.0 bar Range: 3 psid / 0.21 bar

0-30 psig / 0-2.1 bar Range: 5 psid / 0.34 bar



TESCOM 26-2900 Series is a dome loaded, negative bias, backpressure tracking regulator with a balanced main valve. This regulator controls upstream pressures up to 1000 psig / 69.0 bar with spring bias setting.

MEDIA CONTACT MATERIALS

Body

303 Stainless Steel or Brass

Seat

CTFE

Diaphragm

(Unreinforced) Viton-A®

O-Rings

Viton-A®

Back-up Rings

Teflon®

Remaining Parts

300 Series Stainless Steel and Brass

OTHER

Cleaning

CGA 4.1 and ASTM G93

Weight

10 lbs / 4.5 kg

Viton® and Teflon® are registered trademarks of E.I. du Pont de Nemours and Company.

Applications

Constant bias applications:

- Offshore diving applications
- Dumping exhaled breath from pressure chamber (BIBS)
- Diving bell

Features and Benefits

- Balanced stem design eliminates the need to adjust bias over a wide range of operating pressures
- High flow capacity: $C_v = 2.0$
- Diaphragm sensed
- Low accumulation
- Mounts in any position
- Choice of Stainless Steel or Brass construction

26-2900 Series Regulator Drawing

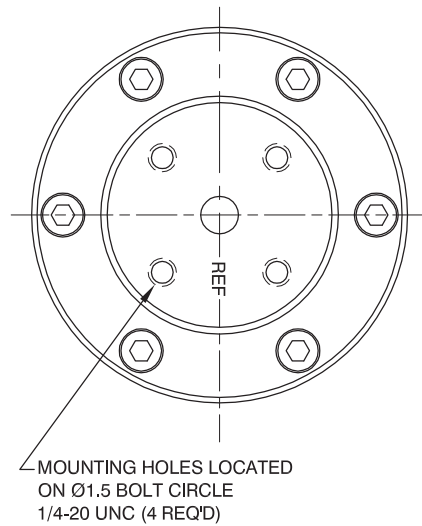
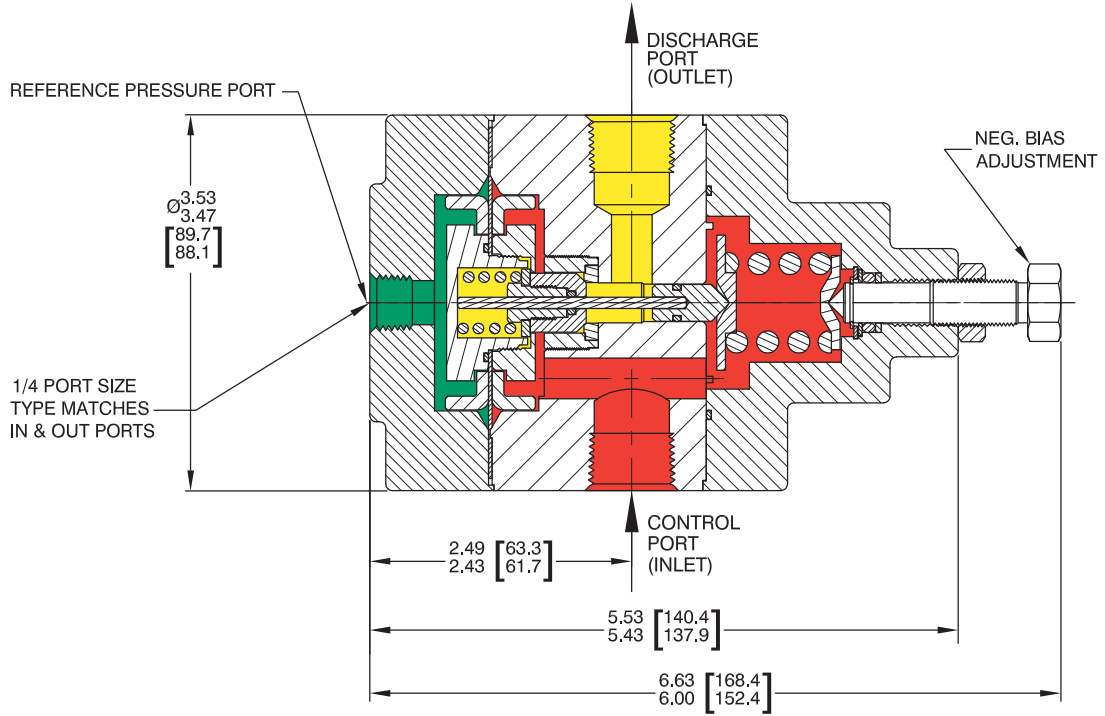

All dimensions are reference & nominal
Metric [millimeter] equivalents are in brackets

26-2900 Series Regulator Flow Chart

For more information on how to read flow curves, please refer to the Flow Curves and Calculations document (debul2007x012) in the TESCOM catalog or on www.tescom.com.

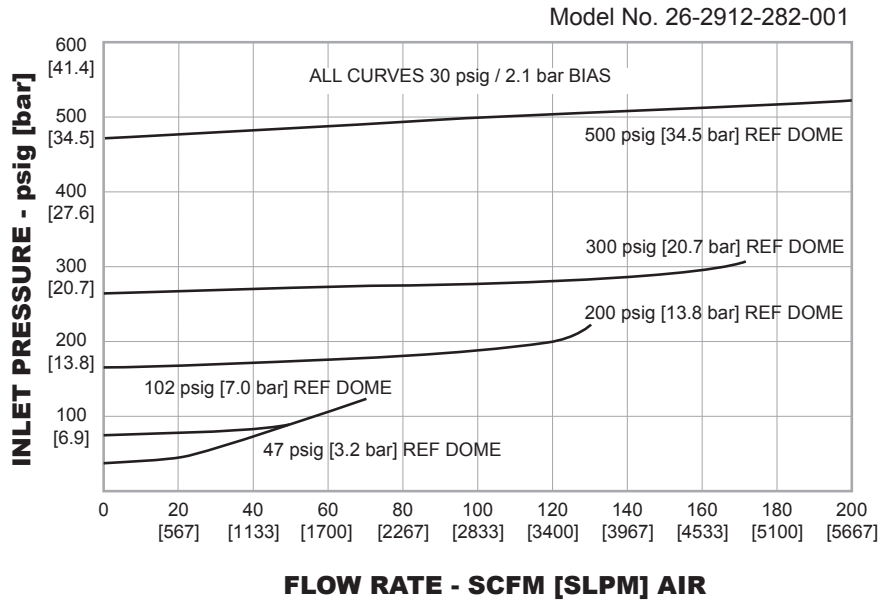

26-2900 Series Regulator Typical Installations

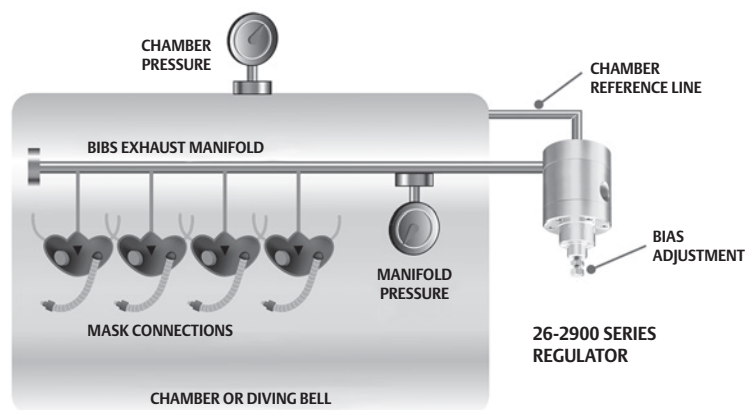

- Dumping exhaled breath out of a pressure chamber (BIBS)
- Constant bias applications such as offshore diving apparatus

26-2900 Series Regulator Part Number Selector

Repair Kits, Accessories & Modifications may be available for this product. Please contact TESCOM for more information.

Example for selecting a part number:

26-29	1	2	-	2	8	2	A
BASIC SERIES	BODY MATERIAL	BIAS PRESSURE RANGE	INLET AND OUTLET PORT TYPE	INLET AND OUTLET PORT SIZE	BIAS MODE	FLOW CAPACITY	
26-29	1 – Brass 2 – 303 Stainless Steel	0 – Zero bias 1 – 0-15 psig / 0-1.0 bar 2 – 0-30 psig / 0-2.1 bar ¹ 0-25 psig / 0-1.7 bar ² 3 – 0-45 psig / 3.1 bar	1 – SAE 2 – NPTF 3 – MS33649 9 – BSP	8 – 1/2"	2 – Negative	A – C _v = 2.0	
		1. Inlet pressures 0-500 psig / 34.5 bar 2. Inlet pressures 500-1000 psig / 34.5-69.0 bar					



WARNING! Do not attempt to select, install, use or maintain this product until you have read and fully understood the *TESCOM Safety, Installation and Operation Precautions*.