

44-4600 Series

Regulators - Pressure Reducing

D44461776X012

Specifications

For other materials or modifications, please consult TESCOM.

OPERATING PARAMETERS

Pressure rating per criteria of ANSI/ASME B31.3

Inlet Pressure Range

Atmospheric to 400 psig / 27.6 bar

Outlet Pressure Range

50 mm Hg absolute - 15 psig / 1.0 bar

Design Proof Pressure

150% maximum rated

Leakage

Internal: Bubble-tight

External: Design to meet: $< 2 \times 10^{-8}$ atm cc/sec He

Operating Temperature

-40°F to 165°F / -40°C to 74°C

Flow Capacity

$C_v = 0.24$

Maximum Operating Torque (handknob)

30 in-lbs / 3.4 N•m

MEDIA CONTACT MATERIALS

Body

316 Stainless Steel

Diaphragm

316 Stainless Steel

Seat

Teflon®

Spring (main valve)

Elgiloy®

Spring (bias)

316 Stainless Steel

Remaining Parts

316 Stainless Steel

OTHER

Cleaning

CGA 4.1 and ASTM G93

Weight (without gauges)

2.75 lbs / 1.2 kg

Teflon® is a registered trademark of E.I. du Pont Nemours and Company.

Elgiloy® is a registered trademark of Elgiloy Corp.



TESCOM 44-4600 Series is an extremely sensitive, high purity, single-stage regulator for specialty, flammable and industrial gases for low pressure and sub-atmospheric pressure control. Diffusion-resistant metal diaphragm seal ensures gas purity and leak integrity.

Applications

- Analytical systems
- Sample systems
- Process systems
- Pilot plants
- Calibration

Features and Benefits

- Optional 3500 psig / 241 bar maximum inlet
- Metal-to-metal sealed diaphragm
- Adjustable stop limits maximum outlet pressure
- 316 Stainless Steel construction
- Available in dome or air load

44-4600 Series Regulator Drawing

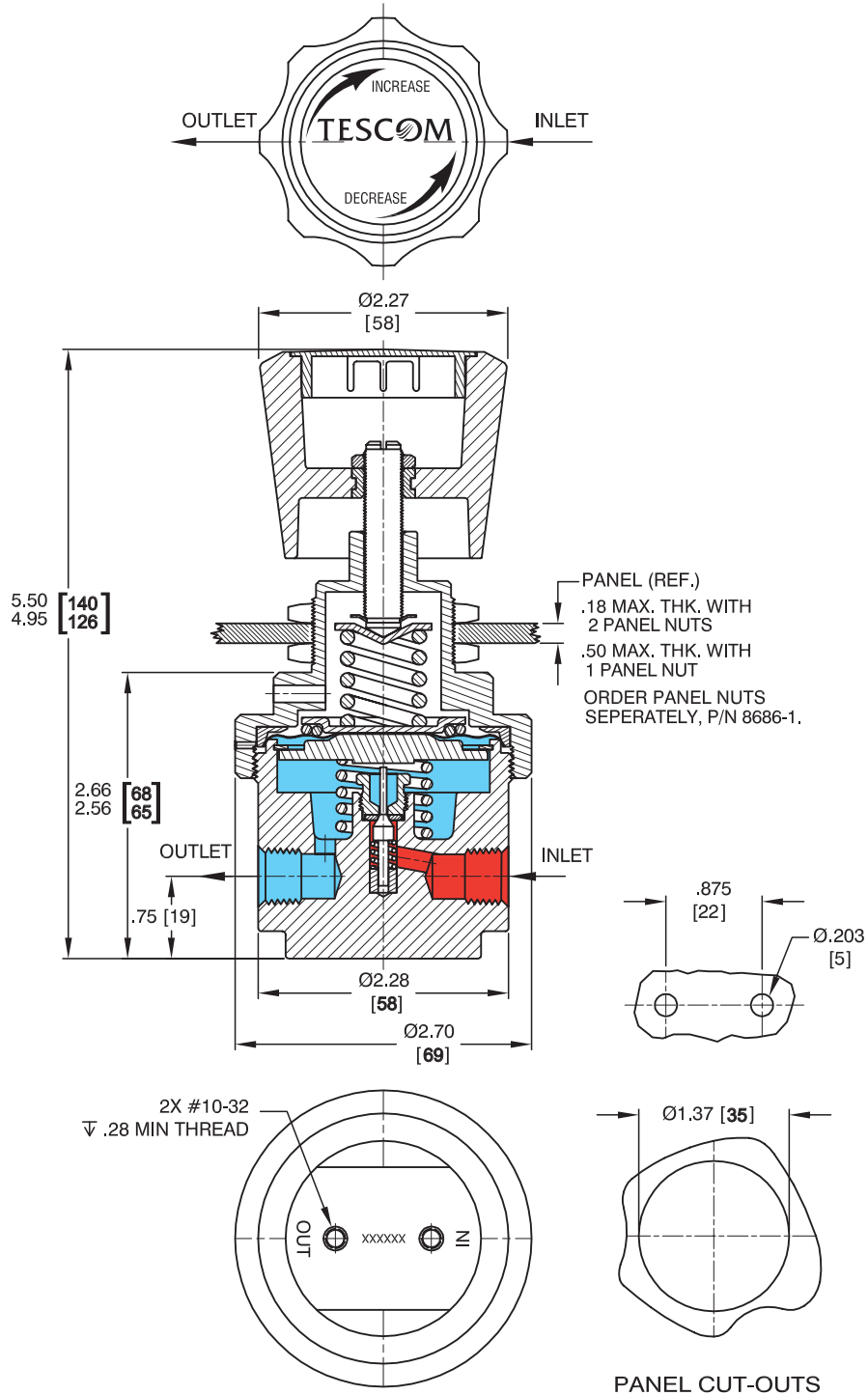

All dimensions are reference & nominal
Metric [millimeter] equivalents are in brackets

44-4600 Series Regulator Flow Chart

For more information on how to read flow curves, please refer to the Flow Curves and Calculations document (debul2007x012) in the TESCOM catalog or on www.tescom.com.

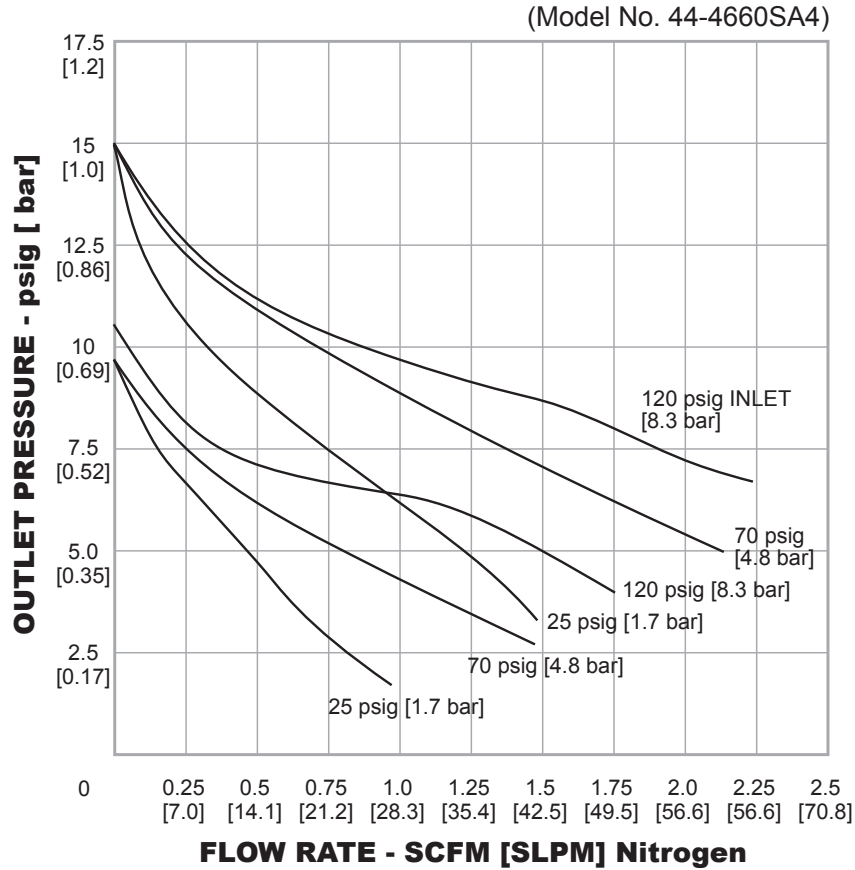

44-4600 Series Typical Application

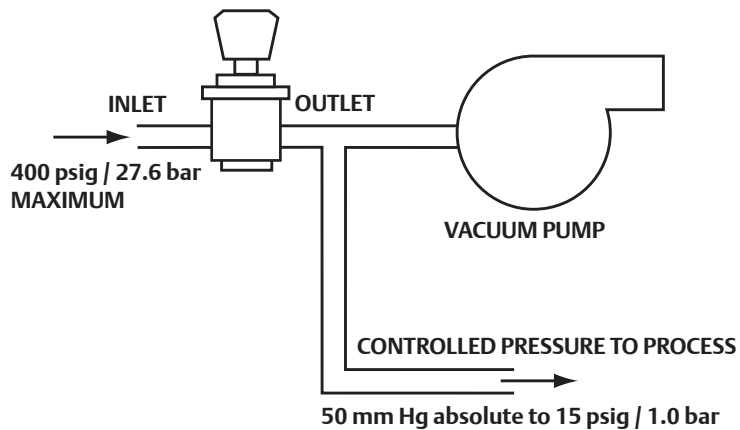

44-4600 Series Regulator Part Number Selector

Repair Kits, Accessories & Modifications may be available for this product. Please contact TESCOM for more information.

Example for selecting a part number:

44-46	6	0	S	2	4	-	See Number Below
BASIC SERIES	BODY MATERIAL	OUTLET PRESSURE RANGE ¹	SOFT GOODS	INLET AND OUTLET PORT TYPE	INLET AND OUTLET PORT SIZE		MODIFICATIONS
44-46	6 – 316 Stainless Steel	0 – 50 mm Hg absolute - 15 psig / 1.0 bar <i>1. 28" Hg = 50 mm Hg absolute</i>	S- Teflon®	2 – NPTF	4 – 1/4"		-001 – One 1/4" gauge port at 90° -002 – Two 1/4" gauge ports at 60° (Spring) -019 – 3500 psig / 241 bar maximum inlet pressure C _v = 0.06



WARNING! Do not attempt to select, install, use or maintain this product until you have read and fully understood the *TESCOM Safety, Installation and Operation Precautions*.

D44461776X012 © 2012 Emerson Process Management Regulator Technologies, Inc. All rights reserved. 05/2012.
Tescom, Emerson Process Management, and the Emerson Process Management design are marks of one of the Emerson Process Management group of companies. All other marks are the property of their respective owners.