

Needle Valves

Block and Bleed

MVBB Series

Pressures to 20,000 psi (1379 bar)

Parker Autoclave Engineers series MVBB block and bleed valve is a two stem manifold valve providing an economical and convenient method of blocking, bleeding and calibrating pressure transmitters and gauges. The valve utilizes the mini valve packing and stem design making it compact and easy to use. The valve can be surface or panel mounted for safe operation. In addition, manifold style valves reduce the number of fittings and space required for installation.

Block and Bleed Features:

- MVBB Series valve design provides large valve performance in a small package
- Tubing sizes: 1/4" and 3/8"
- Rising stem/barstock body design.
- Metal-to-metal seating achieves bubble-tight shut-off, longer stem/seat life in abrasive flow, greater durability for repeated on/off cycles and excellent corrosion resistance.
- PTFE encapsulated packing provides dependable stem and body sealing.
- Stem and packing gland design have been selected to achieve extended thread cycle life and reduced handle torque.

Parker Autoclave Engineers valves are complemented by a complete line of fittings, tubings and accessories. The MVBB Series uses Parker Autoclave Engineers' medium pressure connections. This coned and threaded connection provides a reliable bubble-tight seal for dependable performance in gas or liquid service.



**Autoclave
Engineers** 
www.autoclave.com

Needle Valves - MVBB Series

Pressures to 20,000 psi (1379 bar)



| Tube Outside Diameter Size Inches | Connection Type | Orifice Size Inches (mm) | Rated C_v | Pressure Rating psi (bar) @ Room Temperature** |
|-----------------------------------|-----------------|--------------------------|-------------|--|
| 1/4 | SF250CX | 0.093 (2.36) | 0.20 | 20,000 (1379) |
| 3/8 | SF375CX | 0.093 (2.36) | 0.20 | 20,000 (1379) |

Notes:

** For complete temperature ratings see pressure/temperature rating guide in Technical Information section.

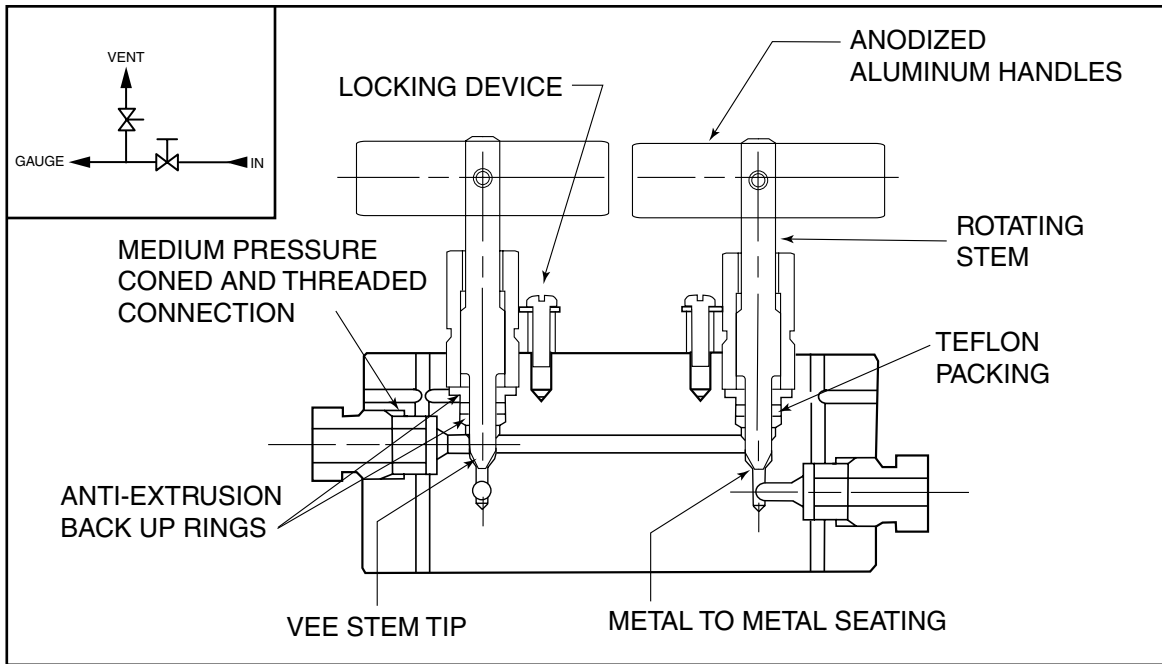

To ensure proper fit use Autoclave tubing

Valve Options

Extreme Temperatures

Standard Parker Autoclave Engineers valves with PTFE packing may be operated to 450°F (232°C). High temperature packing is available for service from 0°F (-17.8°C) to 800°F (427°C) by adding the following suffixes to catalog order number.

TG standard valve with PTFE glass packing to 600°F (316°C)

GY standard valve with Graphite braided yarn packing to 800°F (427°C).

For additional valve options, contact your Sales Representative.

Note: Refer to the Tools, Installation, Operation and Maintenance section for proper maintenance procedures.

| Catalog Number | Stem Type | Outside Diameter Tube | Orifice Diameter | Dimensions - inches (mm) | | | | | | | | | | | | | | | |
|----------------|-----------|-----------------------|------------------|--------------------------|---------|---------|---------|----------------|---------|---------|---------|----------------|---------|---------|---------|---------|-------|-------|--|
| | | | | A | B | C | D | D ₁ | E | F | G | G ₁ | H* | M | N | O | P | Q | |
| 20MVBB | VEE | 1/4 | 0.094 | 3.50 | 0.813 | 0.38 | 0.625 | 0.938 | 1.50 | 1.75 | 0.56 | 0.281 | 2.94 | 2.50 | 0.485 | 1.63 | .500 | 2.625 | |
| | | (6.35) | (2.39) | (88.90) | (20.65) | (9.65) | (15.88) | (23.83) | (38.10) | (44.45) | (14.27) | (7.14) | (74.68) | (63.50) | (12.32) | (41.40) | 12.70 | 66.68 | |
| 20MVBB6 | VEE | 3/8 | 0.094 | 3.88 | 1.00 | 0.44 | 0.625 | 0.938 | 1.50 | 1.75 | 0.56 | 0.281 | 2.94 | 2.88 | 0.50 | 1.63 | .500 | 2.625 | |
| | | (9.53) | (2.39) | (98.60) | (25.40) | (11.10) | (15.88) | (23.83) | (38.10) | (44.45) | (14.27) | (7.14) | (74.68) | (73.15) | (12.70) | (41.40) | 12.70 | 66.68 | |

For complete information on available options, contact your Sales representative. MVBB Series valves are furnished with connection components unless otherwise specified.

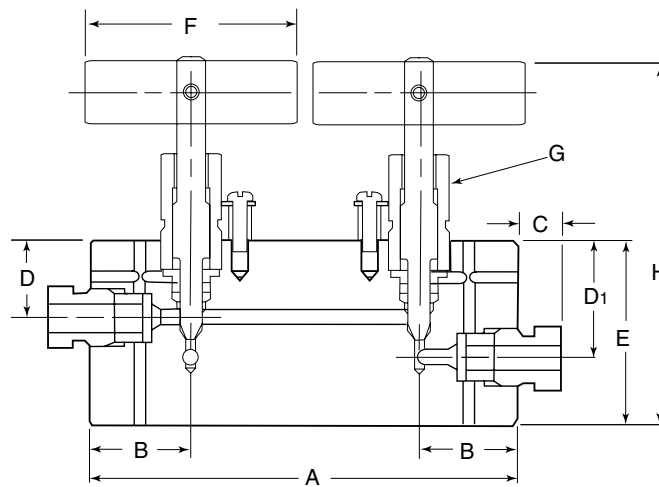
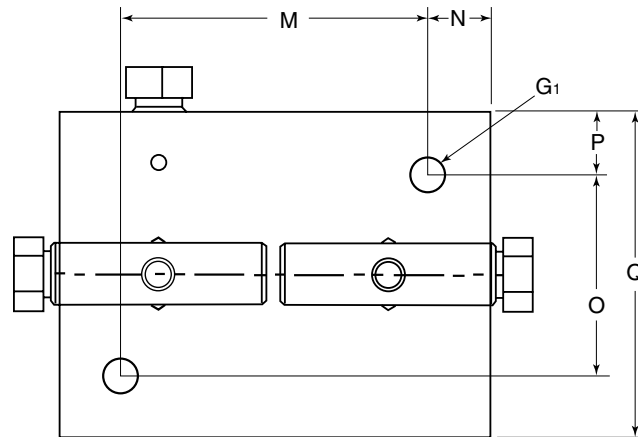

G - Packing gland mounting hole drill size
G₁ - Bracket mounting hole size

* H Dimension is with stem in closed position.
All dimensions for reference only and subject to change.

For prompt service, Parker Autoclave Engineers stocks select products. Consult factory.

WARNING

FAILURE, IMPROPER SELECTION OR IMPROPER USE OF THE PRODUCTS AND/OR SYSTEMS DESCRIBED HEREIN OR RELATED ITEMS CAN CAUSE DEATH, PERSONAL INJURY AND PROPERTY DAMAGE.

This document and other information from Parker Hannifin Corporation, its subsidiaries and authorized distributors provide product and/or system options for further investigation by users having technical expertise. It is important that you analyze all aspects of your application and review the information concerning the product or system in the current product catalog. Due to the variety of operating conditions and applications for these products or systems, the user, through its own analysis and testing, is solely responsible for making the final selection of the products and systems and assuring that all performance, safety and warning requirements of the application are met. The products described herein, including without limitation, product features, specifications, designs, availability and pricing, are subject to change by Parker Hannifin Corporation and its subsidiaries at any time without notice.

Offer of Sale

The items described in this document are available for sale by Parker Hannifin Corporation, its subsidiaries or its authorized distributors. Any sale contract entered by Parker will be governed by the provisions stated in Parker's standard terms and conditions of sale (copy available upon request).



Instrumentation Products Division
Autoclave Engineers Operation
8325 Hessinger Drive
Erie, Pennsylvania 16509-4679 USA
PH: 814-860-5700 FAX: 814-860-5811
www.autoclave.com

Parker Hannifin Manufacturing Ltd.
Instrumentation Products Division, Europe
Industrial Estate Whitemill
Wexford, Republic of Ireland
PH: 353 53 914 1566
FAX: 353 53 914 1582

Caution! Do not mix or interchange parts or tubing with those of other manufacturers. Doing so is unsafe and will void warranty.

Caution! Parker Autoclave Engineers Valves, Fittings and Tools are not designed to work with common commercial instrument tubing and will only work with tubing built to Parker Autoclave Engineers AES Specifications. Failure to do so will void warranty.

ISO-9001 Certified