



Liquid Level Gages and Valves

Forty years of product knowledge brings you the best the market has to offer: Quest Tec Solutions is a young company with a long lineage of quality, experience and care. The development and engineering of the liquid level gage and valve product lines began more than forty years ago.

These products have been consistently refined and improved to remain one of the industry leaders in liquid level measurement. One of the leading liquid measurement companies, Daniel Measurement and Control, directed this product development and engineering.

New management means a fresh dedication to bring you solutions: On September 27, 2001, the Daniel liquid level gage and valve product lines were purchased by Quest Tec Solutions. Quest-Tec is managed by people that have been involved with liquid level products for over 15 years. The management and staff at Quest Tec have collective hands-on experience with all aspects of the liquid level gage and valve product line of over 150 years.

New facilities means flexibility to better meet your needs: Quest Tec relocated its manufacturing facility for better growth and flexibility across Houston to 13960 South Wayside Drive, Houston, TX 77048 with a new phone number of (281) 240-0440. This new facility has also allowed for the expansion into new product offerings such as Magnetic Level gages, High Pressure Steam gages and Electronic Boiler trim.

When choosing your liquid level measurement solution provider, why not choose the best? The symmetry of a market tried-and-true product coupled with the energy of new management, has positioned Quest Tec to be best suited to assist you solve your liquid level measurement challenges.

GLASS-TRAC LIQUID LEVEL GAGES and VALVES

CONTENTS	
REFLEX GAGES	
With Straight-Thru Connections	2
With Close Hook-up Connections	2
Pressure Ratings and Dimensions	3-4
TRANSPARENT GAGES	
With Straight-Thru Connections	5
With Close Hook-up Connections	5
Pressure Ratings and Dimensions	6-7
OFFSET VALVES	
Type 1S and 1U	8
Type 2S and 2U	8
Type 3S and 3U (OS&Y)	9
Type 7S and 7U (OS&Y)	10
STRAIGHT-THRU VALVES	
Type 4S and 4U	11
Type 5S and 5U (OS&Y)	12
TUBULAR GAGES AND VALVES	
Gages	13
Tubular Valves (Brass)	14
Tubular Valves (Type 1T and 2T)	15
SPECIALTY GAGES	
Welding Pad Gages	16
Large Chamber for Viscous Liquids	17-18
Heated/Cooled Externally	19-20
Frost-Prevention Extension	21-22
Illuminators (Explosion-Proof)	23
Quick-Opening Levers	24
DIMENSIONAL DATA	
Flat Gage Glasses	24
Gage Connections	25
Tank Connections	26-27
Installation: Standard Gages	28
Installation: Close Hook-up	29

ORDERING INFORMATION

Please Specify:

- Gage Size Number
- Type of Service
- Temperature Limits
- Pressure Limits
- Type of Connections
- Special Functions
- Vessel Centers if Close Hook-up

GAGE NUMBERING SYSTEM

Example: 71-RL:

7 is #7 Glass (#1 through #9)

1 is One-Section Gage (1, 2, 3, 4, . . .)

R is Reflex (T-Transparent)

L is Low Pressure Series (M = Mid, H = High, WP = Weld Pad)

(Add appropriate digits or letters to indicate special purpose gage or accessory)

HC Externally Heating/Cooling Gages

FP Frost Preventive Extensions

LC Large Chamber Gage

EP Explosion Proof Illuminator

CH Close Hook-up Connections

Carbon steel is the standard material for all Glass-Trac low, mid and high pressure liquid level gages. The percentages of carbon steel pressure ratings for optional gage materials are listed below.

GAGES

Stainless Steel 300 & 400 Types	100%
Monel, Hastelloy B & C	90%
Brass	50%

GASKETS

Special Acid Sheet Gasketing	75%
Teflon®, KEL-F®	50%
Glass Filled Teflon	100%

REFLEX GAGES

Glass-Trac Reflex Gages use prism glass to provide an excellent indication of the liquid level. All liquids appear black in high contrast to the mirror-like surface above. This clean line of separation can be sighted from many yards away. Reflex Gages are made in three pressures series (maximum 4000 psig @ 100°F) and are tapped for ½+ or ¾+ NPT connections. The standard Glass-Trac level gages are designed for minimum -20°F service.

On Glass-Trac Reflex Close Hook-up Gages with ½+ NPT connections, the center-to-center dimensions is the same as the overall length on standard gages. On Close Hook-up Gages with ¾+ NPT connections, the center-to-center dimensions is the same as the overall length on standard gages plus ⅜+.

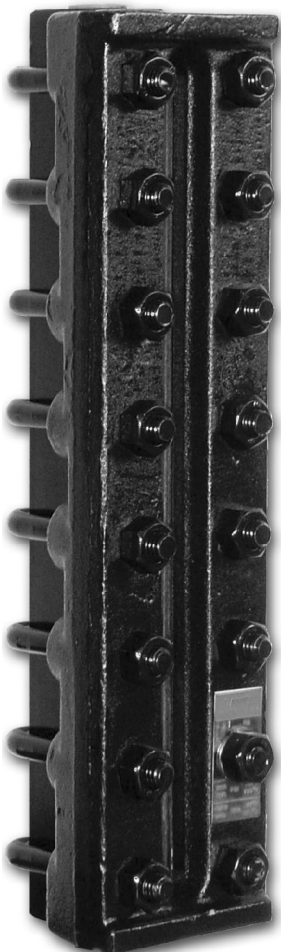

**TYPICAL REFLEX
TOP/BOTTOM**

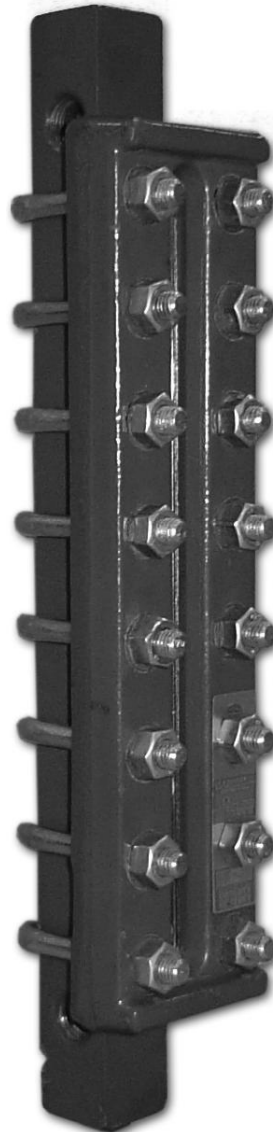

**TYPICAL-REFLEX
CLOSE HOOK-UP**

MATERIALS

BODY (LIQUID CHAMBER): Accurately machined from square tubes to provide perfect seating for gage glasses. Glass is recessed for protection. Body materials include 316 stainless steel and carbon steel.

COVER: Glass-Trac gage covers are made of carbon steel or 316 stainless steel in all their sizes and pressure ratings for higher strength and dependable service. All covers are machined to provide recessed seating protection for the glass.

GLASS: All standard Glass-Trac Reflex Gages use tempered borosilicate glass in nine standard lengths. Each glass has expertly molded reflecting prisms.

GASKETS & CUSHIONS: High grade non-asbestos is used in gaskets and cushions for Glass-Trac gages. The machined recess in the gage body and cover protects the gasket and cushion as well as the glass.

BOLTS: Glass-Trac gage bolts are made of alloy steel, ASTM A-193 Grade B7.

NUTS: Gage nuts are made of steel, ASTM A-194 Grade 2H.

(Torque instructions for gage bolts are on the back cover.)

PRESSURE RATINGS & DIMENSIONS

Reflex Gages (With Straight-Thru Connections)

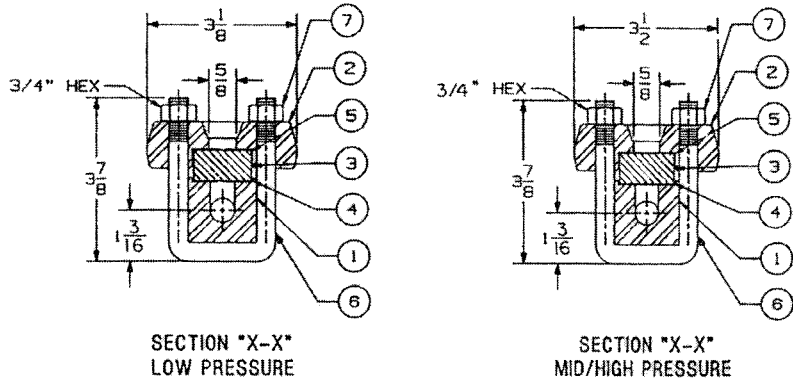

SIZES AND WEIGHTS											
SIZE NUMBERS			OVER-ALL LENGTH (IN.)			VISIBLE GLASS (IN.) B	GLASS SIZE C	CLOSE HOOK-UP CENTER-TO-CENTER (IN.)		APPROX. WT. (LBS.)	
LOW PRESS.	MID-PRESS.	HIGH PRESS.	A (STD)* 1/2" or 3/4" NPT	A (CH) 1/2" NPT	A (CH) 3/4" NPT			D 1/2" NPT	D 3/4" NPT	LOW PRESS.	MID-HIGH PRESS.
SINGLE-SECTION GAGE											
11 RL	11 RM	11 RH	5 1/4	8 7/8	9 1/4	3 3/4	3 3/4	5 1/4	5 5/8	7	8
21 RL	21 RM	21 RH	6 1/4	9 7/8	10 1/4	4 3/4	4 3/4	6 1/4	6 5/8	8	9
31 RL	31 RM	31 RH	7 1/4	10 7/8	11 1/4	5 3/4	5 3/4	7 1/4	7 5/8	9	11
41 RL	41 RM	41 RH	8 1/4	11 7/8	12 1/4	6 3/4	6 3/4	8 1/4	8 5/8	10	12
51 RL	51 RM	51 RH	9 3/8	13	13 3/8	7 7/8	7 7/8	9 3/8	9 3/4	12	14
61 RL	61 RM	61 RH	10 5/8	14 1/4	14 5/8	9 1/8	9 1/8	10 5/8	11	14	16
71 RL	71 RM	71 RH	11 3/4	15 3/8	15 3/4	10 1/4	10 1/4	11 3/4	12 1/8	15	18
81 RL	81 RM	81 RH	13 3/8	17	17 3/8	11 7/8	11 7/8	13 3/8	13 3/4	17	20
91 RL	91 RM	91 RH	14 1/8	17 3/4	18 1/8	12 5/8	12 5/8	14 1/8	14 1/2	18	21
TWO-SECTION GAGE											
32 RL	32 RM	32 RH	14 1/2	18 1/8	18 1/2	13	5 3/4	14 1/2	14 7/8	19	22
42 RL	42 RM	42 RH	16 1/2	20 1/8	20 1/2	15	6 3/4	16 1/2	16 7/8	22	25
52 RL	52 RM	52 RH	18 3/4	22 3/8	22 3/4	17 1/4	7 7/8	18 3/4	19 1/8	24	28
62 RL	62 RM	62 RH	21 1/4	24 7/8	25 1/4	19 3/4	9 1/8	21 1/4	21 5/8	27	32
72 RL	72 RM	72 RH	23 1/2	27 1/4	27 1/2	22	10 1/4	23 1/2	23 7/8	29	35
82 RL	82 RM	82 RH	26 3/4	30 3/8	30 3/4	25 1/4	11 7/8	26 3/4	27 1/8	34	40
92 RL	92 RM	92 RH	28 1/4	31 7/8	32 1/4	26 3/4	12 5/8	28 1/4	28 5/8	37	43
THREE-SECTION GAGE											
63 RL	63 RM	63 RH	31 7/8	35 1/2	35 7/8	30 3/8	9 1/8	31 7/8	32 1/4	41	48
73 RL	73 RM	73 RH	35 1/4	38 7/8	39 1/4	33 3/4	10 1/4	35 1/4	35 5/8	45	53
83RL	83 RM	83 RH	40 1/8	43 3/4	44 1/8	38 5/8	11 7/8	40 1/8	40 1/2	52	60
93 RL	93 RM	93 RH	42 3/8	46	46 3/8	40 7/8	12 5/8	42 3/8	42 3/4	55	64
FOUR-SECTION GAGE											
74 RL	74 RM	74 RH	47	50 5/8	51	45 1/2	10 1/4	47	47 3/8	60	71
84 RL	84 RM	84 RH	53 1/2	57 1/8	57 1/2	52	11 7/8	53 1/2	53 7/8	69	80
94 RL	94 RM	94 RH	56 1/2	60 1/8	60 1/2	55	12 5/8	56 1/2	56 7/8	72	85
FIVE-SECTION GAGE											
75 RL	75 RM	75 RH	58 3/4	62 3/8	62 3/4	57 1/4	10 1/4	58 3/4	59 1/8	74	88
85 RL	85 RM	85 RH	66 7/8	70 1/2	70 7/8	65 3/8	11 7/8	66 7/8	67 1/4	86	100
95 RL	95 RM	95 RH	70 5/8	74 1/4	74 5/8	69 1/8	12 5/8	70 5/8	71	90	106

*3/4" NPT Tapped High Pressure Gages Add "1 1/2" to 'A' Dimension.

Reflex Gages (With Close Hook-Up Connections)

PARTS		
ITEM NO.	NAME	MATERIAL
1	CHAMBER	CARBON STEEL
2	COVER	CARBON STEEL
3	GLASS	TEMPERED
4	GASKET	NON-ASBESTOS
5	CUSHION	NON-ASBESTOS
6	BOLT	ASTM A193 B7
7	NUT	ASTM A194 2H

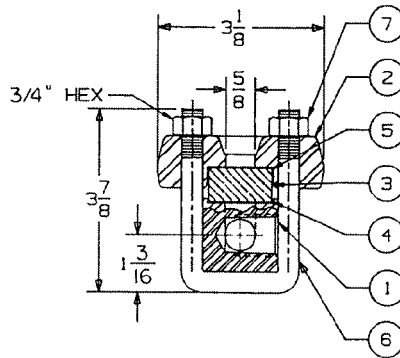

SECTION "X-X"
LOW PRESSURE

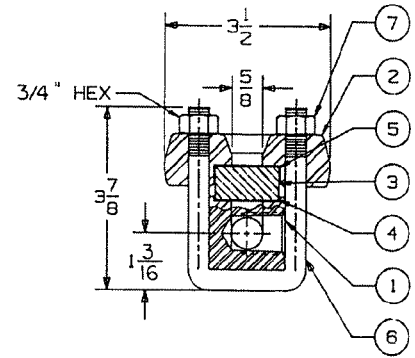

SECTION "X-X"
MID/HIGH PRESSURE

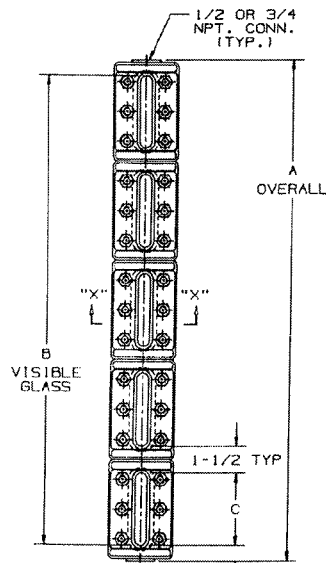

STANDARD
3/4 TYP.
(1-1/2 FOR HI-PRESS.
WITH 3/4 NPT CONN.)

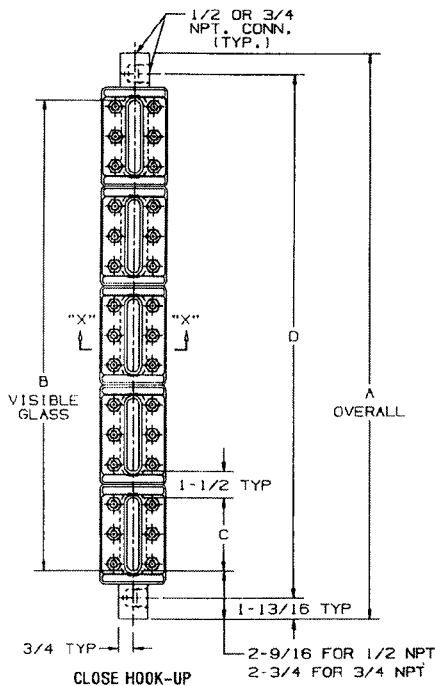

CLOSE HOOK-UP

PRESSURE RATINGS AT ° F*							
LOW PRESSURE GAGE**							
Glass Size	100°	200°	300°	400°	500°	600°	700°
1	2400	2320	2240	2150	2000	1780	1520
2	2325	2250	2170	2090	1940	1720	1470
3	2250	2180	2100	2020	1880	1670	1420
4	2175	2100	2020	1940	1820	1600	1370
5	2100	2030	1960	1880	1750	1550	1320
6	2025	1950	1890	1810	1680	1500	1280
7	1950	1890	1820	1750	1630	1440	1230
8	1875	1820	1750	1680	1560	1390	1180
9	1800	1740	1680	1620	1510	1340	1140
MID-PRESSURE GAGE**							
Glass Size	100°	200°	300°	400°	500°	600°	700°
1	3000	2900	2800	2690	2500	2220	1890
2	2910	2820	2720	2600	2420	2150	1840
3	2820	2720	2625	2530	2350	2080	1780
4	2725	2640	2560	2460	2270	2040	1740
5	2630	2540	2460	2360	2190	1950	1660
6	2535	2450	2360	2270	2110	1875	1600
7	2440	2360	2280	2190	2030	1805	1540
8	2345	2270	2190	2110	1960	1740	1480
9	2250	2180	2100	2020	1880	1670	1420
HIGH PRESSURE GAGE**							
Glass Size	100°	200°	300°	400°	500°	600°	700°
ALL	4000	3890	3790	3700	3470	3080	2530

*Gages for service to 800° F are available. Consult the factory for the application and ratings.

** Saturated steam to 300 WSP. Above 300 WSP, use transparent gage with mica shields.

TRANSPARENT GAGES

Glass-Trac Transparent Gages use clear, see-through glass on both sides so that both the color and the interface of liquids can be viewed. Electric lighted gage illuminators are available for use on Transparent Gages and provide easy viewing of liquid levels in dimly lighted areas. Transparent Gages are made in three pressure series (maximum 3000 psig @ 100°F) and are tapped for ½+ or ¾+ NPT connections. The standard Glass-Trac level gages are designed for -20°F service.

On Glass-Trac Transparent Close Hook-up Gages with ½+ NPT connections, the center-to-center dimension is the same as the overall length on standard gages. On Close Hook-up Gages with ¾+ NPT connections the center-to-center dimensions is the same as the overall length on standard gages plus ¾+.

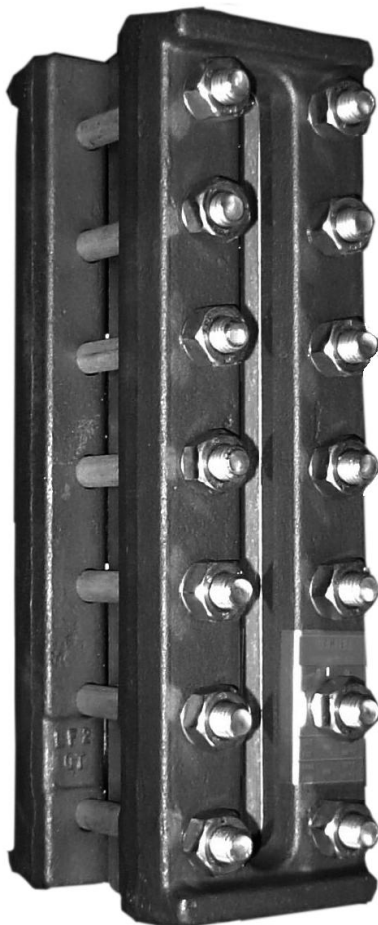

TYPICAL TRANSPARENT TOP/BOTTOM



TYPICAL TRANSPARENT CLOSE HOOK-UP

MATERIALS

BODY (LIQUID CHAMBER): Accurately machined from square tubes to provide perfect seating for gasket, and gage glasses. Both glasses are recessed for protection. Body materials include Type 316 stainless steel and carbon steel.

COVERS: Both covers on transparent gages are carefully machined to provide perfect seating for cushions and gage glasses. This machining also provides deep recessed seating in the cover for added glass protection. Covers are available in Type 316 stainless steel and in carbon steel.

GLASS: All standard Glass-Trac Transparent Gages use tempered borosilicate glass in nine standard lengths. Each transparent glass is crystal clear and has the highest strength possible.

GASKET & CUSHIONS: High grade non-asbestos is used in gaskets and cushions for Glass-Trac gages. The machined recess in the gage body and cover protects the gasket and cushion as well as the glass.

BOLTS: Glass-Trac gage bolts are made of alloy steel, ASTM A-193 Grade B7.

NUTS: Gage nuts are made of steel, ASTM A-194 Grade 2H.

(Torque instructions for gage bolts are on Back Cover.)

PRESSURE RATINGS & DIMENSIONS:

Transparent Gages (With Straight-thru Connections)

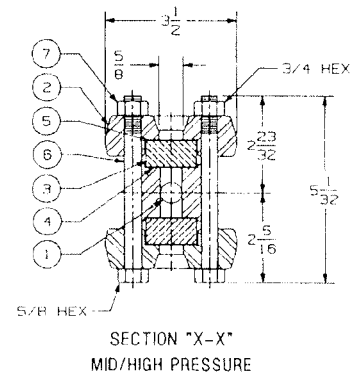
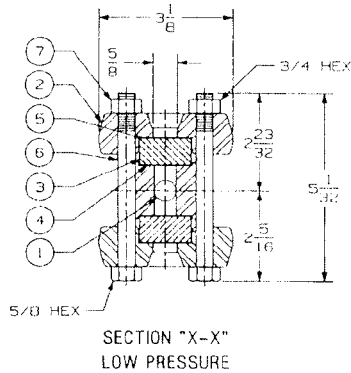

SIZES AND WEIGHTS											
SIZE NUMBERS			OVER-ALL LENGTH (IN.)			VISIBLE GLASS (IN.)	GLASS SIZE C	CLOSE HOOK-UP CENTER-TO-CENTER (IN.)		APPROX. WT. (LBS)	
LOW PRESS.	MID-PRESS.	HIGH PRESS.	A(STD)* 1/2 OR 3/4 NPT	A(CH) 1/2 NPT	A(CH) 3/4 NPT			D 1/2" NPT	D 3/4" NPT	LOW PRESS.	MID-HIGH PRESS.
SINGLE SECTION GAGE											
11 TL	11 TM	11 TH	5 1/4	8 7/8	9 1/4	3 3/4	3 3/4	5 1/4	5 5/8	10	12
21 TL	21 TM	21 TH	6 1/4	9 7/8	10 1/4	4 3/4	4 3/4	6 1/4	6 5/8	11	14
31 TL	31 TM	31 TH	7 1/4	10 7/8	11 1/4	5 3/4	5 3/4	7 1/4	7 5/8	14	17
41 TL	41 TM	41 TH	8 1/4	11 7/8	12 1/4	6 3/4	6 3/4	8 1/4	8 5/8	16	19
51 TL	51 TM	51 TH	9 3/8	13	13 3/8	7 7/8	7 7/8	9 3/8	9 3/4	17	21
61 TL	61 TM	61 TH	10 5/8	14 1/4	14 5/8	9 1/8	9 1/8	10 5/8	11	19	24
71 TL	71 TM	71 TH	11 3/4	15 3/8	15 3/4	10 1/4	10 1/4	11 3/4	12 1/8	21	27
81 TL	81 TM	81 TH	13 3/8	17	17 3/8	11 7/8	11 7/8	13 3/8	13 3/4	24	30
91 TL	91 TM	91 TH	14 1/8	17 3/4	18 1/8	12 5/8	12 5/8	14 1/8	14 1/2	26	32
TWO-SECTION GAGE											
32 TL	32 TM	32 TH	14 1/2	18 1/8	18 1/2	13	5 3/4	14 1/2	14 7/8	27	33
42 TL	42 TM	42 TH	16 1/2	20 1/8	20 1/2	15	6 3/4	16 1/2	16 7/8	32	38
52 TL	52 TM	52 TH	18 3/4	22 3/8	22 3/4	17 1/4	7 7/8	18 3/4	19 1/8	36	43
62 TL	62 TM	62 TH	21 1/4	24 7/8	25 1/4	19 3/4	9 1/8	21 1/4	21 5/8	40	49
72 TL	72 TM	72 TH	23 1/2	27 1/4	27 1/2	22	10 1/4	23 1/2	23 7/8	43	54
82 TL	82 TM	82 TH	26 3/4	30 3/8	30 3/4	25 1/4	11 7/8	26 3/4	27 1/8	50	61
92 TL	92 TM	92 TH	28 1/4	31 7/8	32 1/4	26 3/4	12 5/8	28 1/4	28 5/8	51	64
THREE-SECTION GAGE											
63 TL	63 TM	63 TH	31 7/8	35 1/2	35 7/8	30 3/8	9 1/8	31 7/8	32 1/4	59	73
73 TL	73 TM	73 TH	35 1/4	38 7/8	39 1/4	33 3/4	10 1/4	35 1/4	35 5/8	63	80
83 TL	83 TM	83 TH	40 1/8	43 3/4	44 1/8	38 5/8	11 7/8	40 1/8	40 1/2	75	92
93 TL	93 TM	93 TH	42 3/8	46	46 3/8	40 7/8	12 5/8	42 3/8	42 3/4	78	97
FOUR-SECTION GAGE											
74 TL	74 TM	74 TH	47	50 5/8	51	45 1/2	10 1/4	47	47 3/8	85	107
84 TL	84 TM	84 TH	53 1/2	57 1/8	57 1/2	52	11 7/8	53 1/2	53 7/8	100	122
94 TL	94 TM	94 TH	56 1/2	60 1/8	60 1/2	55	12 5/8	56 1/2	56 7/8	104	129
FIVE-SECTION GAGE											
75 TL	75 TM	75 TH	58 3/4	62 3/8	62 3/4	57 1/4	10 1/4	58 3/4	59 1/8	106	134
85 TL	85 TM	85 TH	66 7/8	70 1/2	70 7/8	65 3/8	11 7/8	66 7/8	67 1/4	124	152
95 TL	95 TM	95 TH	70 5/8	74 1/4	74 5/8	69 1/8	12 5/8	70 5/8	71	129	161

*3/4 "NPT Tapped High Pressure Gages Add 1 1/2" to 'A' Dimensions.

Transparent Gages (With Close Hook-up Connections)

PARTS		
ITEM NO.	NAME	MATERIAL
1	CHAMBER	CARBON STEEL
2	COVER	CARBON STEEL
3	GLASS	TEMPERED
4	GASKET	NON-ASBESTOS
5	CUSHION	NON-ASBESTOS
6	BOLT	ASTM A193 B7
7	NUT	ASTM A194 2H

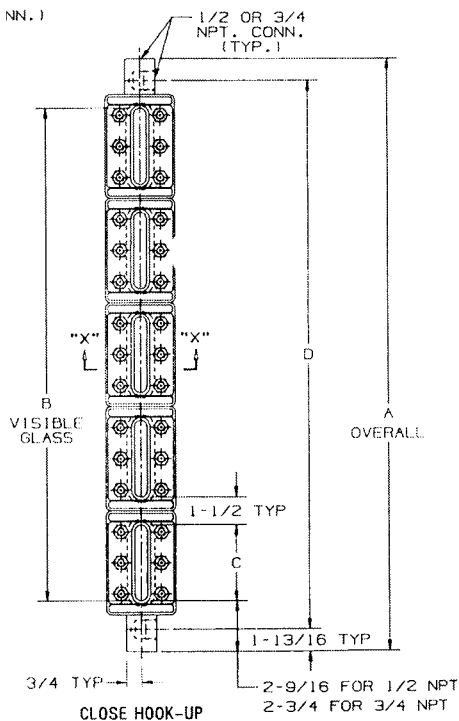
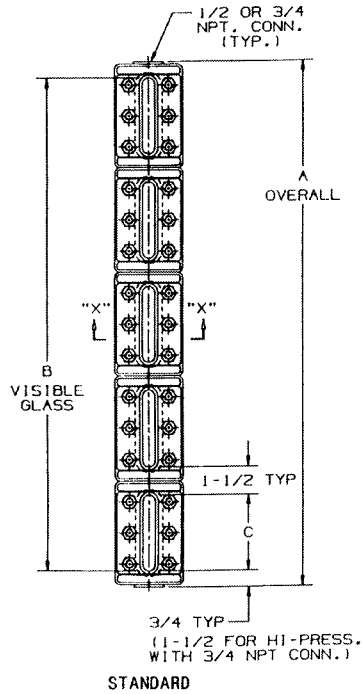
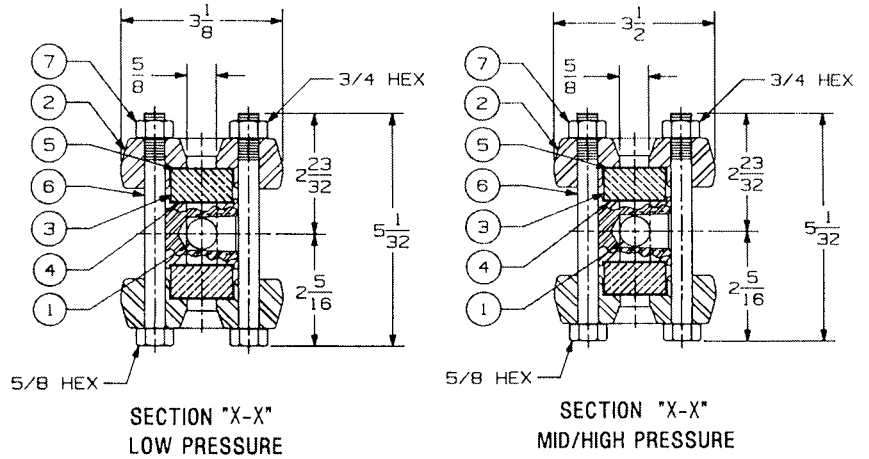

PRESSURE RATINGS AT ° F*							
LOW PRESSURE GAGE**							
GLASS SIZE	100°	200°	300°	400°	500°	600°	700°
1	2000	1935	1870	1790	1660	1480	1260
2	1815	1750	1690	1620	1510	1340	1150
3	1630	1580	1520	1460	1360	1210	1050
4	1440	1390	1340	1290	1200	1060	900
5	1250	1210	1170	1120	1040	920	790
6	1065	1030	995	950	890	790	680
7	875	845	815	785	730	645	550
8	690	665	645	620	575	510	440
9	500	480	465	445	415	370	320
Maximum Saturated Steam 350 WSP							
MID-PRESSURE GAGE**							
GLASS SIZE	100°	200°	300°	400°	500°	600°	700°
1	2500	2420	2340	2240	2080	1850	1580
2	2315	2250	2170	2090	1940	1720	1470
3	2130	2060	1990	1910	1770	1575	1340
4	1940	1875	1810	1740	1620	1435	1230
5	1750	1690	1630	1570	1460	1295	1100
6	1565	1510	1460	1400	1305	1160	990
7	1375	1330	1280	1230	1145	1015	870
8	1190	1150	1110	1065	990	880	750
9	1000	970	935	895	835	740	630
Maximum Saturated Steam 750 WSP with Mica Shield							
HIGH PRESSURE GAGE**							
GLASS SIZE	100°	200°	300°	400°	500°	600°	700°
ALL	3000	2920	2850	2780	2600	2310	1890

*Gages for service up to 800°F are available. Consult the factory for application and ratings.

OFFSET VALVES

TYPE 1S & 1U

SCREWED BONNET

TYPE 2S & 2U

UNION REPLACEABLE SEAT

4000 psig CWP 6000 psig Test

3/4" NPT Male Union Tank Connection

1/2" NPT Female Gage Connection

1/2" NPT Female Drain Connection

PRESSURE - TEMPERATURE RATING			
Teflon Packing		Wire-Graphite Packing	
4000 psi	100° F	2950 psi	500° F
3730 psi	200° F	2700 psi	600° F
3470 psi	300° F	2430 psi	700° F
3200 psi	400° F		

Glass-Trac Type 1 & 2 Offset Gage Valves are available with screwed (S), union (U), (illustrated below) and tubular (T) gage connections (Page 15). Both 1 and 2 Valves are used with Reflex and Transparent Gages in working pressures up to 4000 psi and with Tubular Gages to their maximum rating. The Teflon packing ring is standard and used in services up to 450° F. For temperatures to 700° F, valves are fitted with special wire graphite packing. Both valves have stainless steel ball checks to shut off the flow automatically in case of gage glass breakage.

The "offset" feature permits easy cleaning of gages. A floating tailpiece on Type 1 valves permits an overall vertical adjustment of 1/8" if the gage center-to-centers are not precisely located. Installation is quicker and gage strain is eliminated.

Type 2 Valves have an optional backseating stem allowing the packing to be changed without shutting down the vessel.

PARTS

ITEM NO	NAME	STANDARD	316 SS WETTED PARTS
		MATERIAL	MATERIAL
1	BODY	CARBON STEEL	316 SS
2	UNION NUT	CARBON STEEL	CARBON STEEL
3	PACKING NUT	CARBON STEEL	CARBON STEEL
4	PACKING FOLLOWER	316 SS	316 SS
5	PACKING RING	TEFLON	TEFLON
6	PACKING WASHER	17-4 PH SS	17-4 PH SS
7	STEM	416 SS	316 SS
8	STEM NUT	CARBON STEEL	CARBON STEEL
9	NAME PLATE	304 SS	304 SS
10	HAND WHEEL	IRON	IRON

ITEM NO	NAME	STANDARD	316 SS WETTED PARTS
		MATERIAL	MATERIAL
11	BALL	440 SS	316 SS
12	BALL RETAINER	316 SS	316 SS
13	MALE CONNECTOR	CARBON STEEL	316 SS
14	BONNET	416 SS	316 SS
15	SEAT	416 SS	316 SS
17	FEMALE CONNECTOR	CARBON STEEL	316 SS

*Item No. 13 has hole with 1/16 eccentricity for ± 1/8 maximum misalignment on the overall center-to-center. Note: Valve shown is for bottom left hand (or top right hand) location. Opposite hand is reversed. Valves are furnished in pairs of one bottom left hand and one top left hand.

Type 1S

Weight per set approximately 10 lbs. 6ozs.

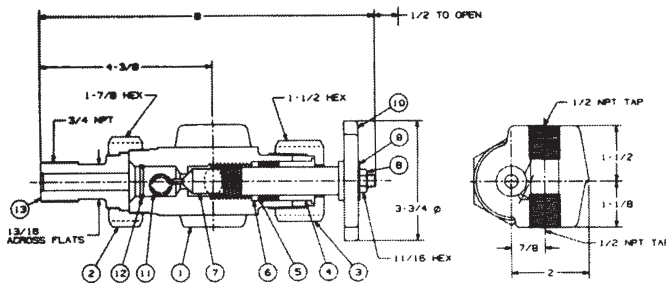

Type 1U

Weight per set approximately 11 lbs. 6 ozs.

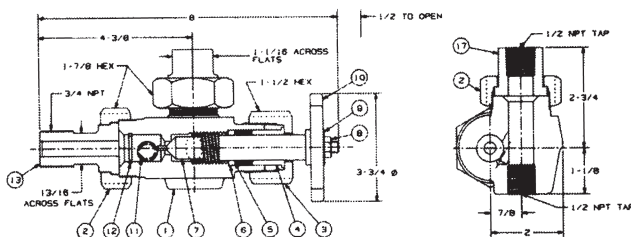

Type 1T Tubular Gage Valve shown on page 15. Optional Gage Connections shown on page 25. Optional Tank Connections shown on pages 26 and 27.

Type 2S

Weight per set approximately 11 lbs. 6 ozs.

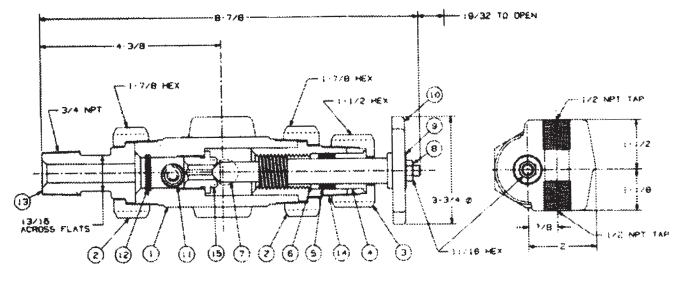

Type 2U

Weight per set approximately 12 lbs. 6 ozs.

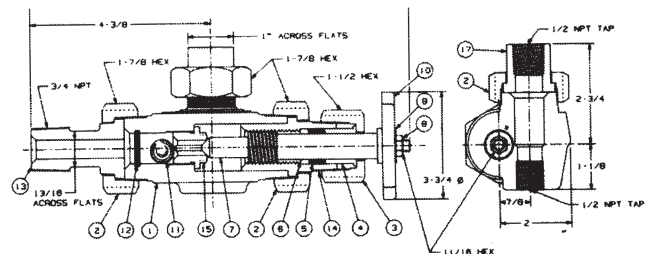

Type 2T Tubular Gage Valve shown on page 15. Optional Gage Connections shown on page 25. Optional Tank Connections shown on pages 26 and 27. Optional Quick Opening Valve shown on page 24.

OFFSET OS&Y VALVES

TYPE 3S & 3U

HEAVY DUTY OUTSIDE SCREW & YOKE

4000 psig CWP 6000 psig Test
 1/2", 3/4" (Std.) or 1" NPT or IPS Solid Shank Tank Connection or Flanged Tank Connection
 1/2" NPT Female Gage Connection
 1/2" NPT Female Drain Connection

PRESSURE - TEMPERATURE RATING			
Teflon Packing		Wire-Graphite Packing	
4000 psi	100° F	2950 psi	500° F
3730 psi	200° F	2700 psi	600° F
3470 psi	300° F	2430 psi	700° F
3200 psi	400° F		

The Glass-Trac Type 3 Offset Gage Valve has the Outside Screw & Yoke design which prevents excessively hot and corrosive fluids from contracting stem threads, causing possible malfunction. The stem backs directly off the regrindable valve seat using the positive, non-rotating stem principle. The valve is offset for ease in gage cleaning and comes in both screwed (S) and a union (U) gage as standard. On special order, tubular (T) gage or other type connection can be supplied. Type 3 valves are used with Reflex and Transparent Gages in working pressures up to 4000 psi.

The standard tank connection for Type 3 OS&Y Offset Gage valves is a 3/4" NPT solid shank, with optional 1/2" and 1" NPT sizes. Ends beveled for welding also are available. Valve materials include forged carbon steel and 316 stainless steel. A molded Teflon packing ring is standard at no extra cost in valves for services up to 450° F. For temperatures to 700° F, valves have wire-graphite packing. The Type 3 valve has stainless steel safety ball checks to shut off the flow automatically in case of gage glass breakage.

PARTS

ITEM NO	NAME	STANDARD	316 SS WETTED PARTS
		MATERIAL	MATERIAL
1	BODY	CARBON STEEL	316 SS
2	PACKING FOLLOWER	316 SS	316 SS
*3	PACKING RING	TEFLON	TEFLON
4	PACKING WASHER	17-4 PH SS	17-4 PH SS
5	STEM	416 SS	316 SS
6	STEM NUT	CARBON STEEL	CARBON STEEL
7	NAME PLATE	304 SS	304 SS
8	BALL	440 SS	316 SS
9	SEAT	416 SS	316 SS
10	FEMALE CONNECTOR	CARBON STEEL	316 SS

ITEM NO	NAME	STANDARD	316 SS WETTED PARTS
		MATERIAL	MATERIAL
11	YOKE	FORGED STEEL	316 SS
12	YOKE GASKET	ASB-304 SS	ASB-304 SS
*13	YOKE SCREW	CARBON STEEL	CARBON STEEL
14	PRESSURE BAR	FORGED STEEL	FORGED STEEL
**15	PRESS BAR SCREW	ALLOY STEEL	ALLOY STEEL
16	INNER THRUST WASHER	17-4 PH SS	17-4 PH SS
17	HANDWHEEL ASSY.	IRON	IRON
18	OUTER THRUST WASHER	17-4 PH SS	17-4 PH SS

* 4 REQUIRED
 ** 2 REQUIRED

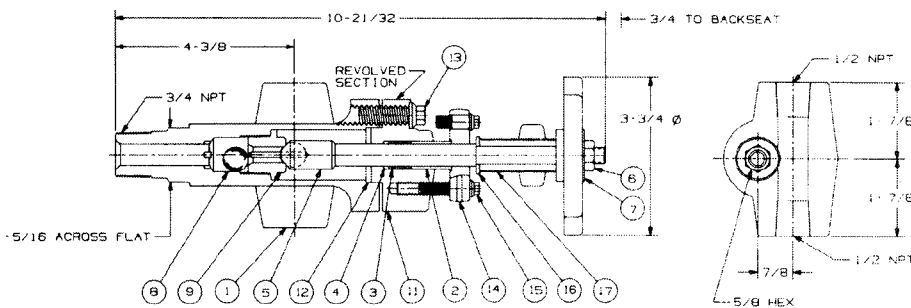

TYPE 3S
 Weight per set approximately 17 lbs. 8 ozs.

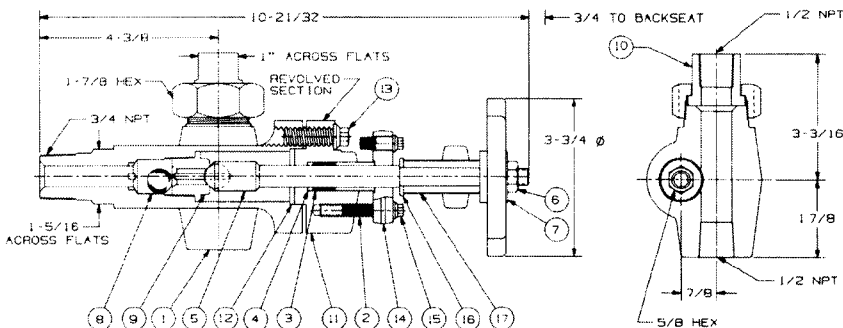

TYPE 3U
 Weight per set approximately 17 lbs. 8ozs.

A Tubular Gage Connection is available on request. Optional Tank Connections shown on pages 26 and 27. Optional Gage Connections shown on page 25.

OFFSET OS&Y VALVES

TYPE 7S & 7U

STANDARD OUTSIDE SCREW & YOKE

1440 psig CWP, 2160 psig Test (600 lbs. Class)
 3/4" NPT Male Tank Connection
 1/2" NPT Female Union Gage Connection

PRESSURE - TEMPERATURE RATING			
Teflon Packing		Wire-Graphite Packing	
1440 psi	100° F	1250 psi	500° F
1400 psi	200° F	1110 psi	600° F
1365 psi	300° F	1065 psi	700° F
1330 psi	400° F		

The Glass-Trac Type 7 Offset Gage Valve features the Outside Screw & Yoke (OS&Y) design which prevents excessively hot and corrosive fluids from contacting stem threads. The stem uses the positive non-rotating stem principle and backs directly off the regrindable seat. This valve is offset for ease in gage cleaning and is available in screwed (S) and union (U) gage connections. The Type 7 Valve also has a backseating stem as a standard feature. Stainless steel ball checks are available upon request.

PARTS

ITEM NO	NAME	MATERIAL
1	BODY	CARBON STEEL
2	UNION NUT	CARBON STEEL
3	PACKING FOLLOWER	STEEL
4	PACKING RING	TEFLON
5	STEM	416 SS
6	STEM NUT	CARBON STEEL
7	SEAT	416 SS
8	FEMALE CONNECTOR	CARBON STEEL
9	YOKE	FORGED STEEL

ITEM NO	NAME	MATERIAL
10	YOKE GASKET	SPIRAL ASB-304 SS
11	YOKE BOLT	ALLOY STEEL
12	PRESSURE BAR	FORGED STEEL
13	PRESSURE BAR SCREW	ALLOY STEEL
14	STEM-SCREW-HANDLE	304 SS
15	NAME PLATE ASSEMBLY	IRON/304 SS
15	OUTER THRUST WASHER	STEEL

NOTE: Valve shown is for bottom left hand (or top right hand) location. Opposite and is reversed. Valves are furnished in pairs of one bottom left hand and one top left hand.

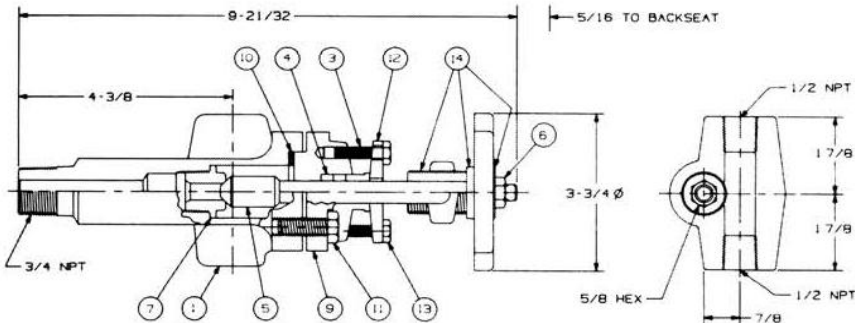

TYPE 7S
 Weight per set approximately 12 lbs

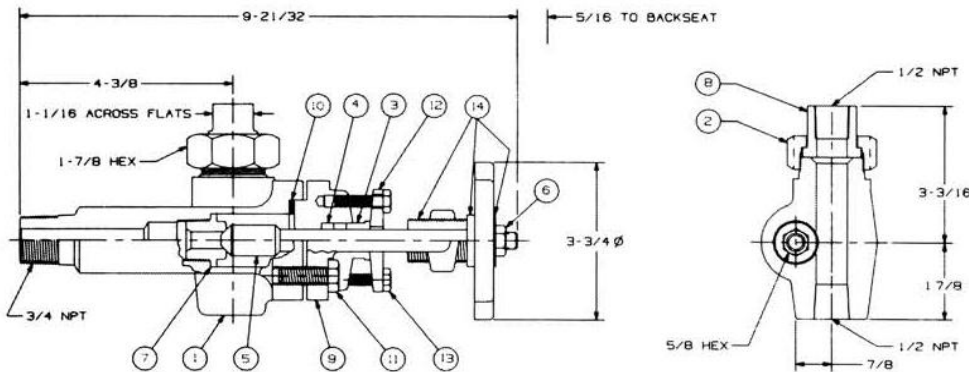

TYPE 7U
 Weight per set approximately 12 lbs.

A Tubular Gage Connection is available on request. Optional Gage Connections shown on page 25. Optional Tank Connections shown on pages 26 and 27. A Ball Check Valve is available on request.

STRAIGHT-THRU VALVES

Type 4S & 4U

RENEWABLE INTERNAL STEM BONNET

4000 psig CWP 6000 psig Test
 3/4" NPT Male Union Tank Connection
 1/2" NPT Female Gage Connection
 1/2" NPT Female Drain Connection

The Glass-Trac Type 4 Straight-Thru Gage Valve is available with screwed (S) and Union (U) gage connections and used with Reflex and Transparent Gages in working pressures up to 4000 psi. The "straight-thru" valve body design is popularly used with close hook-up (side connection) gages because the gage side connection centers and vessel centers can be identical. (With offset valves, vessel centers must be inside or outside side connection centers.) Type 4 Valves have a 3/4" NPT Male Tank Connection as standard, with other connections available on order.

Type 4 Straight-Thru Gage Valves are stocked in carbon steel with stainless steel trims. A molded Teflon packing ring is standard at no extra cost in valves for services to 450°F. For temperatures to 700° F, valves have wire-graphite packing. The Type 4 Valve has stainless steel ball checks to shut off the flow automatically in case of gage glass breakage. An optional back seating stem is available on request.

PRESSURE - TEMPERATURE RATING			
Teflon Packing		Wire-Graphite Packing	
4000 psi	100° F	2950 psi	500° F
3730 psi	200° F	2700 psi	600° F
3470 psi	300° F	2430 psi	700° F
3200 psi	400° F		

PARTS

ITEM NO	NAME	STANDARD	316 SS WETTED PARTS
		MATERIAL	MATERIAL
1	BODY	CARBON STEEL	316 SS
2	UNION NUT	CARBON STEEL	CARBON STEEL
3	PACKING NUT	CARBON STEEL	CARBON STEEL
4	PACKING FOLLOWER	316 SS	316 SS
5	PACKING RING	TEFLON	TEFLON
6	PACKING WASHER	17-4 PH SS	17-4 PH SS
7	STEM	416 SS	316 SS
8	STEM NUT	CARBON STEEL	CARBON STEEL
9	NAME PLATE	304 SS	304 SS
10	HAND WHEEL	IRON	IRON

ITEM NO	NAME	STANDARD	316 SS WETTED PARTS
		MATERIAL	MATERIAL
11	BALL	440 SS	316 SS
12	BALL RETAINER	316SS	316 SS
*13	MALE CONNECTOR	CARBON STEEL	316 SS
14	BONNET	416 SS	316 SS
15	SEAT	416 SS	316 SS
16	FEMALE CONNECTOR	CARBON STEEL	316 SS

* Item No. 13 has hole with 1/16 eccentricity for ± 1/8 maximum misalignment on the overall center-to-center.

Note: Valve shown is for bottom left-hand (or top right-hand) location. Opposite hand is reversed. Valves are furnished in pairs of one bottom left hand and one top left hand.

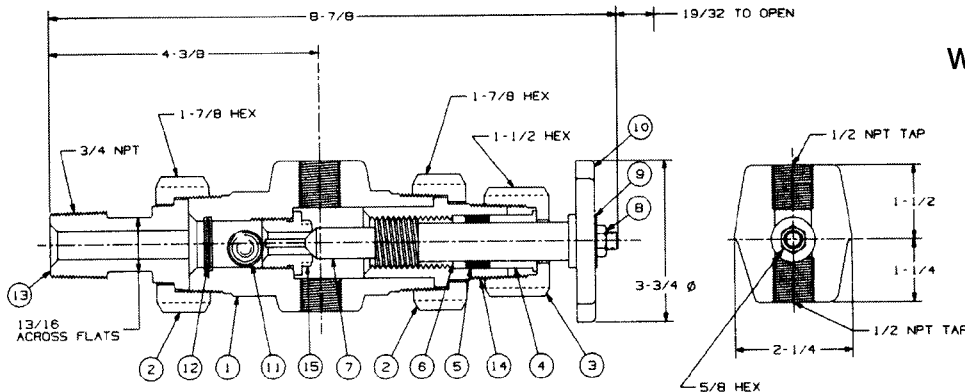

TYPE 4S
 Weight per set approximately 12 lbs.

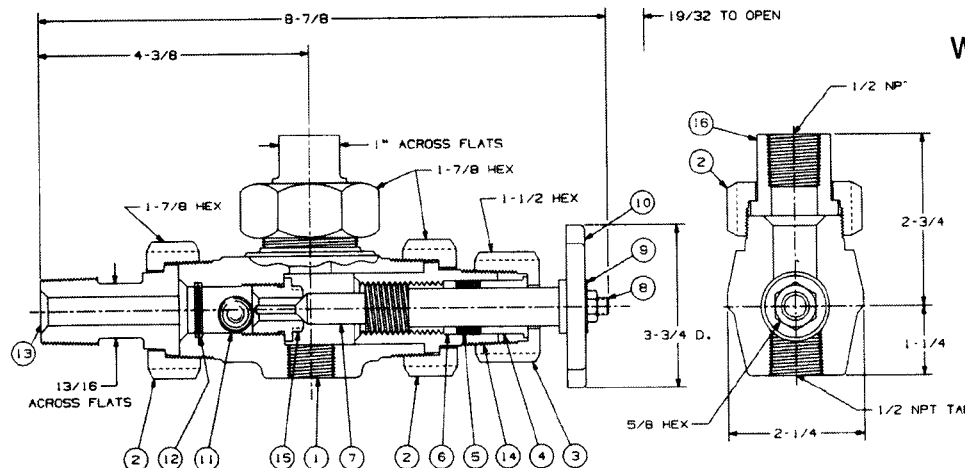

TYPE 4U
 Weight per set approximately 12 lbs.

A Tubular Gage Connection is available on request. Optional Tank Connections shown on pages 26 and 27. Optional Gage Connections shown on page 25. Quick Opening Valve model shown on page 24.

STRAIGHT-THRU OS&Y VALVES

Type 5S & 5U

STANDARD OUTSIDE SCREW & YOKE

1440 psig CWP, 2160 psig Test (600 lbs. Class)

3/4" NPT Male Tank Connection

1/2" NPT Female Gage Connection

1/2" NPT Female Drain Connection only

The Glass-Trac Type 5 Gage Valve has the Outside Screw & Yoke design which prevents excessively hot and corrosive fluids from contacting stem threads, causing possible malfunction. The stem backs directly off the regrindable valve seat using the positive, non-rotating stem principle. The valve has a "straight-thru" body design and, with an optional bleed valve, can be used in a block and bleed application. Standard gage connections are screwed (S) and union (U) but any other type connection can be supplied on special order.

The standard tank connection for Type 5 OS&Y Straight-Thru Gage Valves is a 3/4" NPT solid shank, with optional 1/2" and 1" NPT sizes. Ends beveled for welding also are available. Valve materials include forged carbon steel with stainless steel trims. A molded Teflon packing ring is standard at no extra cost in valves for services up to 450°F. For temperatures to 700°F, valves have wire-graphite packing. The standard Type 5 Valve has a back seating stem that allows the packing to be changed without shutting down the vessel. Stainless steel ball checks are available upon request.

PRESSURE - TEMPERATURE RATING			
Teflon Packing		Wire-Graphite Packing	
1440 psi	100° F	1250 psi	500° F
1400 psi	200° F	1110 psi	600° F
1365 psi	300° F	1065 psi	700° F
1330 psi	400° F		

PARTS

ITEM NO	NAME	MATERIAL
1	BODY	CARBON STEEL
2	UNION NUT	CARBON STEEL
3	PACKING FOLLOWER	STEEL
4	PACKING RING	TEFLON
5	STEM	416 SS
6	STEM NUT	CARBON STEEL
7	SEAT	416 SS
8	FEMALE CONNECTOR	CARBON STEEL

ITEM NO	NAME	MATERIAL
9	YOKE	FORGED STEEL
10	YOKE GASKET	SPIRAL ASB-304 SS
11	YOKE BOLT	ALLOY STEEL
12	PRESSURE BAR	FORGED STEEL
13	PRESSURE BAR SCREW	ALLOY STEEL
	STEM-SCREW-HANDLE	304 SS
14	NAME PLATE ASSEMBLY	IRON/304 SS
15	OUTER THRUST WASHER	STEEL

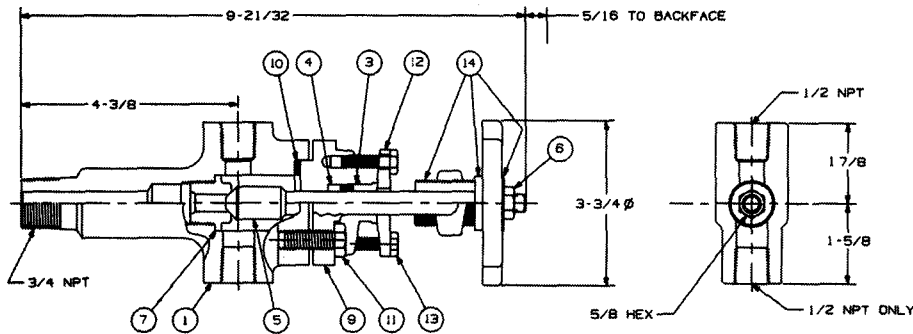

TYPE 5S
Weight per set approximately 12 lbs.

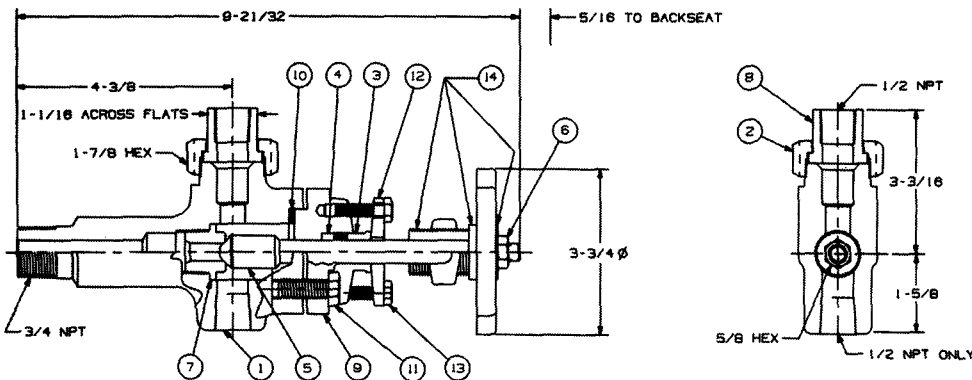

TYPE 5U
Weight per set approximately 12 lbs.

1/2" NPT & 1" NPT OPTIONAL.
1/2" IPS & 1" IPS BEVELED
ENDS OPTIONAL.

A Tubular Gage Connection is available on request. Optional Tank Connections shown on pages 26 and 27. Optional Gage Connection shown on page 25. A Ball Check Valve is available on request.

TUBULAR GAGES AND VALVES

5/8" O.D. Glass Standard, 3/4" O.D. Glass Optional



Shown with Type 2T valves

Glass-Trac Tubular Glass Gages are available in any length desired and can be fitted with Type 1T or 2T Gage Valves (see Page 18). These gages provide 360° visibility of the liquid level through strong, clear glass. Tubular glass is used in three types: Red Line, High Pressure and Heavy Wall. Pressure ratings are different for each type and also depend upon glass length (see next page). If glass breakage occurs, a stainless steel ball check shuts off each valve. Glass tubes should be cut 1 1/2+ shorter than valve center-to-center. The resulting visible glass length is 5+less than the valve center-to-center.

Red Line glass provides a bright crimson stripe against a narrow white strip throughout the length of the tube. Liquid levels are easy to see against this special optical effect. The glass is heat-resistant and ends are fire polished. Red Line is available in both 5/8+and 3/4+O.D.

High Pressure glass is a versatile, medium-strong type of tube used in many applications. It is crystal clear and ends are fire polished.

Heavy Wall glass has the highest pressure rating of all tubular glass. It is extremely clear, corrosion resistant, will not scratch easily and is extra resistant to heat shock. Ends are ground.

Four carbon steel guard rods and two guard rod rings are used to protect tubular glass gages. The rods are anchored in each ring which is fastened to the valve behind the union nut. Rods should be cut 1 3/4+ shorter than valve center-to-center. A transparent plastic sheath also is available to clamp around the glass tube. Sheath length should be 4 3/8+ shorter than valve center-to-center. Also available is an expanded metal gage glass protector for additional protection of the glass. Specify gage valve center-to-center for proper sizing of this assembly.

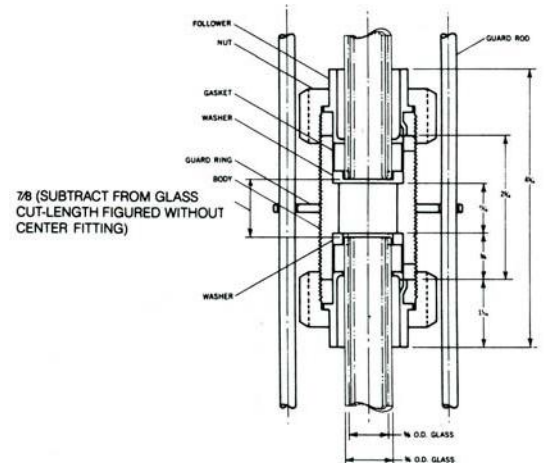
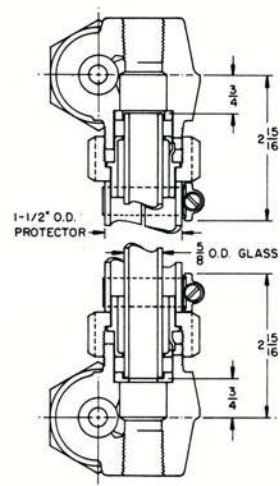
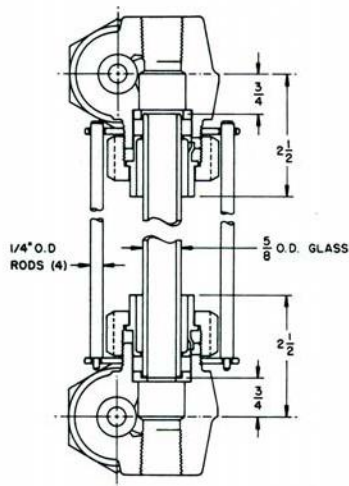

CENTER FITTING
(Recommended when valve centers exceed maximum recommended service length)

NOTE: Type 1T 4000 psi Tubular Valve and Type 2T 4000 psi Tubular Valve shown on page 15.

MAXIMUM RECOMMENDED WORKING PRESSURE, PSIG

GLASS LENGTH	5/8" O.D. RED LINE		3/4" O.D. RED LINE		5/8" O.D. HIGH PRESSURE	
	TO 150° F*	TO 425° F**	TO 150° F*	TO 425° F**	TO 150° F*	TO 425° F**
8"	370	285	360	280	435	320
10"	345	280	340	275	420	315
12"	335	280	330	275	410	305
14"	325	275	320	270	390	295
15"	320	275	315	270	380	290
16"	315	270	310	265	375	285
18"	305	265	300	260	360	280
20"	290	265	285	260	350	270
22"	280	260	275	255	335	265
24"	265	255	260	250	320	255
30"	235	†	230	†	280	†
36"	205	†	200	†	245	†
48"	165	†	160	†	195	†
60"	125	†	125	†	150	†
72"	90	†	90	†	100	†

GLASS LENGTH	3/4" O.D. HIGH PRESSURE		5/8" O.D. HEAVY WALL		3/4" O.D. HEAVY WALL	
	TO 150° F*	TO 425° F**	TO 150° F*	TO 425° F**	TO 150° F*	TO 425° F**
8"	425	315	600	350	600	350
10"	410	310	600	345	600	345
12"	400	300	600	340	600	340
14"	385	290	600	335	600	335
15"	375	285	600	330	600	330
16"	370	280	600	325	600	325
18"	355	275	600	320	600	320
20"	345	265	600	315	600	315
22"	330	260	590	310	590	310
24"	315	250	580	300	580	300
30"	275	†	550	†	550	†
36"	240	†	500	†	500	†
48"	190	†	340	†	340	†
60"	145	†	†	†	†	†
72"	100	†	†	†	†	†

*To 150°F and/or CORROSIVE SERVICES **For 150-425° and/or CORROSIVE SERVICES
 † Maximum recommended length in this service is 24".
 ‡ Maximum recommended length in this service is 48".

TUBULAR VALVES (Brass)

1/2" NPT Male Tank Connection
5/8" O.D. Tubular Glass Gage Connection

For low pressure water vessels, storage tanks, containers, etc., Glass-Trac provides Type OT Brass Valves for Tubular Gages. The valves are made up with 5/8" O.D. Pyrex Red Line, High Pressure or Heavy Wall Glass from stock. Each valve contains a brass ball check which closes the valve in the event of glass breakage. Two guard rods are used. The lower valve also is fitted with a threaded drain cock. Type OT Brass Valves are suitable for working pressures up to 200 psig at or under 400°F.

Tubular glasses are available in any length and should be cut 1 1/2" shorter than valve center-to-center. Guard rods should be 3/4" longer than the valve center-to-centers.

Visible length is 3" less than the valve centers.

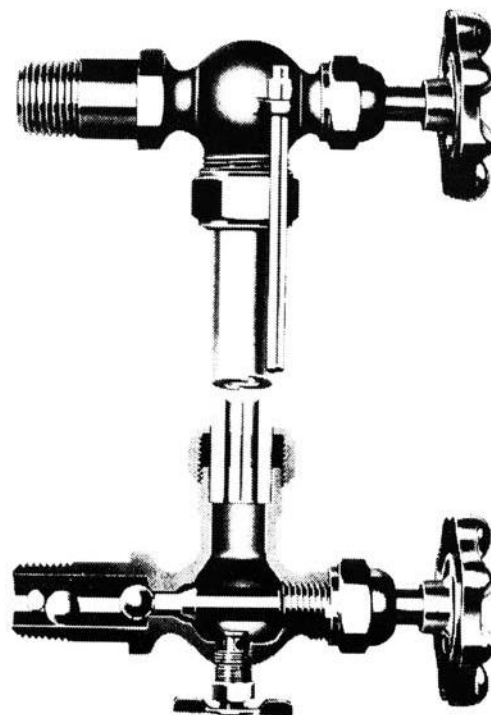

TUBULAR VALVES

Type 1T & 2T

4000 psig CWP 6000 psig Test
 3/4" NPT Male Union Tank Connection
 3/4" O.D. Tubular Glass Gage Connection
 1/2" NPT Female Drain Connection

Glass-Trac Offset Tubular Gage Valves are identical to Type 1 and 2 S and U Valves except they are fitted with the 3/8" O.D. tubular glass connection. The Type 2T Valve also can be furnished in the coarse thread design and with quick-operating lever for remote operation by chain. Both valves have a molded Teflon packing ring and rubber glass gaskets as standard for services up to 250° F. For temperatures to 425° F, valves have wire-graphite packing and Viton® glass gaskets. In the event of tubular glass breakage, a stainless steel ball check closes the valve to prevent further loss of fluid.

PRESSURE - TEMPERATURE RATING			
Teflon Packing		Wire-Graphite Packing	
4000 psi	100 F	3470 psi	300 F
3730 psi	200 F	3200 psi	* 400 F
3600 psi	250 F	3150 psi	425 F

NOTES: These ratings are for the valves only and not the tubular glass gages. See glass gage ratings on page 14.

PARTS

ITEM NO	NAME	STANDARD	316 SS WETTED PARTS
		MATERIAL	MATERIAL
1	BODY	CARBON STEEL	316 SS
2	UNION NUT	CARBON STEEL	CARBON STEEL
3	PACKING NUT	CARBON STEEL	CARBON STEEL
4	PACKING FOLLOWER	316 SS	316 SS
5	PACKING RING	TEFLON	TEFLON
6	PACKING WASHER	17-4 PH SS	17-4 PH SS
7	STEM	416 SS (1)	316 SS
8	STEM NUT	CARBON STEEL	CARBON STEEL
9	NAME PLATE	4165	304 SS
10	HAND WHEEL	ALLOY ZINC	ALLOY ZINC
11	BALL	440 SS	440 SS
12	BALL RETAINER	316 SS	316 SS

ITEM NO	NAME	STANDARD	316 SS WETTED PARTS
		MATERIAL	MATERIAL (2)
*13	MALE CONNECTOR	CARBON STEEL	316 SS
14	BONNET (2)	416 SS	316 SS
15	SEAT (2)	416 SS	316 SS
16	GLASS FOLLOWER	CARBON STEEL	CARBON STEEL
17	GLASS GASKET	RUBBER	RUBBER
**18 OR 19	LOWER GLASS SUPPORT	CARBON STEEL	316 SS

* ITEM NO.13 HAS HOLE WITH 1/16 ECCENTRICITY FOR ± 1/8 MAXIMUM MISALIGNMENT ON THE OVERALL CENTER-TO-CENTER.

**ITEM NO.21 IS USED IN LOWER VALVE ; ITEM NO.20 IN UPPER VALVE.

NOTE: Valve shown is for bottom left hand (or top right hand) location. Opposite hand is reversed. Valves are furnished in pairs of one bottom left hand and one top left hand.

(1) For Type 1 - 416 SS

(2) Available in Type 2 Valve only.

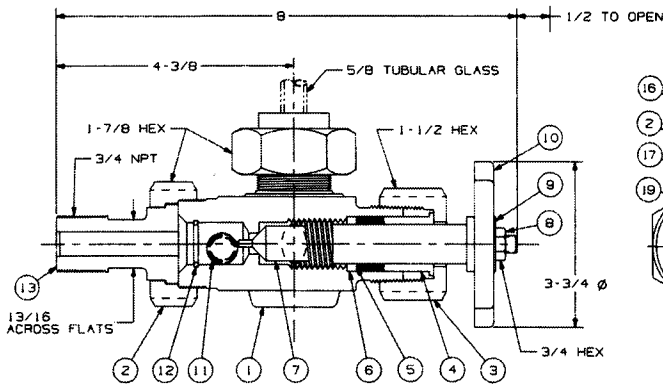

TYPE 1T
 Weight per set approximately 10 lbs. 12ozs.

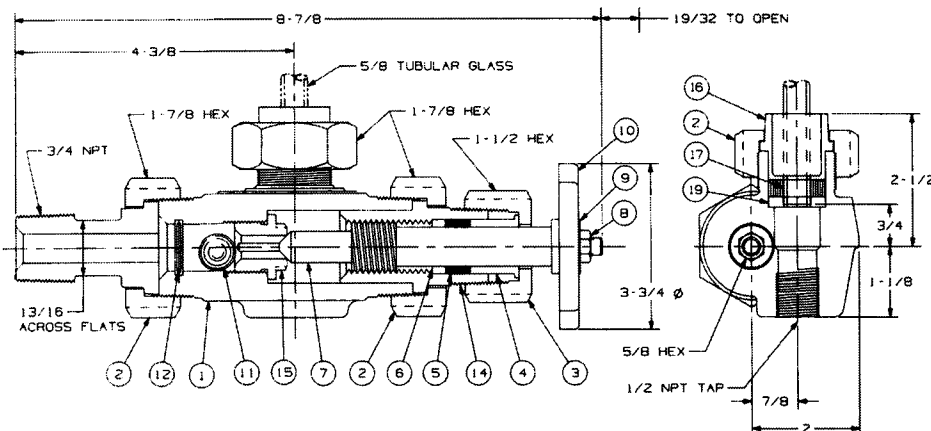

TYPE 2T
 Weight per set approximately 11 lbs. 12ozs.

Optional Tank Connections shown on pages 26 and 27. Optional Gage Connections shown on page 25.

SPECIALTY GAGES:

Welding Pad

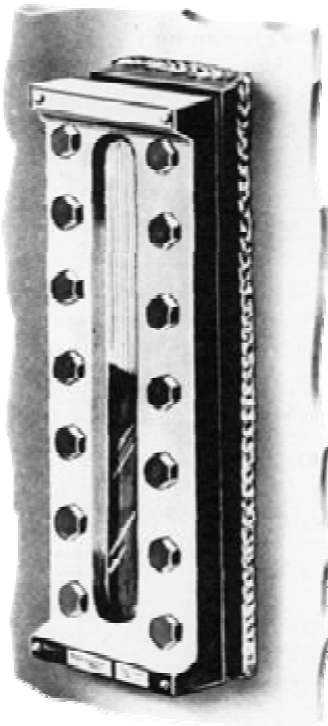

Glass-Trac Welding Pad Gages are used when standard tank connections cannot be used or when the liquid has solids in suspension. The gage becomes an integral part of the vessel because it is welded right onto the outer wall. Reflex or Transparent glass is used in any of nine standard lengths. Standard covers are 3 1/8" wide. **NOTES:** Welding pad gages to be used on vessels less than 36" in diameter must be special ordered. The welding pad body must be machined to allow proper fit up.

Method of Installation:

1. Assemble complete gage with spacer plate (available on request) in place of gage glass.
2. Place gage in exact location desired on empty vessel and weld around circumference of the pad.
3. Allow gage to cool, then remove cover and spacer. Drill or burn top and bottom holes in vessel wall at the top and bottom of each gage slot. Slot is 5/8" wide.
4. Replace gage glass, gasket, cushion and cover. Torque bolts to prescribed foot/pounds.

NOTES: While the gage itself can be designed to withstand certain pressures. Glass-Trac cannot control the installation of each gage or the load applied to the gage by the vessel. Because of this, Glass-Trac cannot rate Weld Pad Gages.

When ordering, add WP to gage size number.

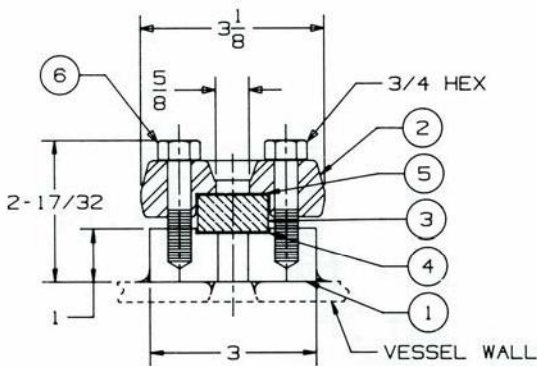

SECTION X-X
REFLEX

PARTS

ITEM NO.	NAME	MATERIAL
1	WELDING PAD	AISI 1020 HR
2	COVER	CARBON STEEL
3	GLASS	TEMPERED
4	GASKET	NON-ASBESTOS
5	CUSHION	NON-ASBESTOS
6	BOLT	ASTM A193 B7

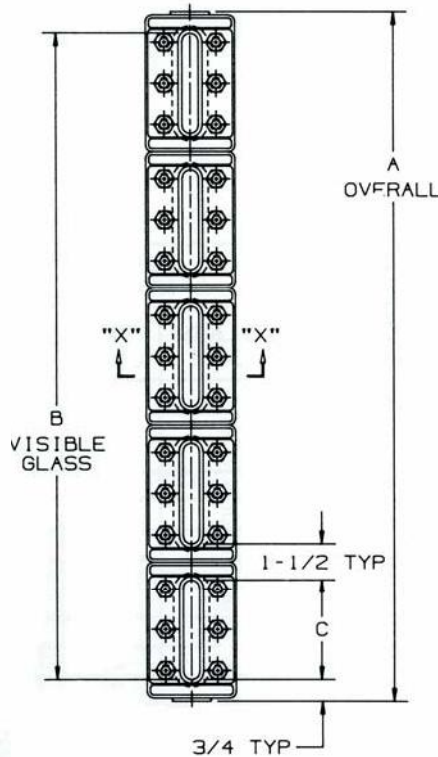

DIMENSIONS

SIZE NO.		DIMENSIONS (IN INCHES)		
GLASS SIZE	NO. SEC T.	A	B	C
1	1	5 1/4	3 3/4	3 3/4
2	1	6 1/4	4 3/4	4 3/4
3	1	7 1/4	5 3/4	5 3/4
4	1	8 1/4	6 3/4	6 3/4
5	1	9 3/8	7 7/8	7 7/8
6	1	10 5/8	9 1/8	9 1/8
7	1	11 3/4	10 1/4	10 1/4
8	1	13 3/8	11 7/8	11 7/8
9	1	14 1/8	12 5/8	12 5/8
3	2	14 1/2	13	5 3/4
4	2	16 1/2	15	6 3/4
5	2	18 3/4	17 1/4	7 7/8
6	2	21 1/4	19 3/4	9 1/8
7	2	23 1/2	22	10 1/4
8	2	26 3/4	25 1/4	11 7/8
9	2	28 1/4	26 3/4	12 5/8
6	3	31 7/8	30 3/8	9 1/8
7	3	35 1/4	33 3/4	10 1/4
8	3	40 1/8	38 5/8	11 7/8
9	3	42 3/8	40 7/8	12 5/8
7	4	47	45 1/2	10 1/4
8	4	53 1/2	52	11 7/8
9	4	56 1/2	55	12 5/8
7	5	58 3/4	57 1/4	10 1/4
8	5	66 7/8	65 3/8	11 7/8
9	5	70 5/8	69 1/8	12 5/8

SPECIALTY GAGES:

Large-Chamber

Example: 71 RL-LC (No.7 glass, 1-section, Reflex, Low Pressure, Large Chamber)



Glass-Trac Large Chamber Gages are made in a special low pressure series of both Reflex and Transparent Gages. The large diameter chamber makes accurate liquid level readings possible under unusual conditions such as boiling, flashing, or foaming of the liquid. The chamber is manufactured from heavy duty seamless steel pipe with an inside diameter of 2 $\frac{1}{8}$ +. Each end of the pipe is closed off with a welded plug which is drilled and tapped for $\frac{3}{4}$ + NPT connections. For close hook-ups, $\frac{3}{4}$ +NPT side connections are made and ends may be drilled, tapped and plugged for cleaning as required.

Recessed seats are machined into the liquid chamber and gage covers for protection of glass, gasket and cushion. Special bolts are used. Large Chamber Gages are made in lengths for standard flat glasses and multiple section gages are available.

When ordering, add LC for large chamber to gage size number and CH for close hook-up.

DIMENSIONS

SIZE NO.		DIMENSIONS (IN INCHES)							
GLASS SIZE	NO. SECT.	STANDARD			CLOSE HOOK-UP				
		A	B	C	A	B	C	D	
1	1	6 1/4	3 3/4	3 3/4	8 3/8	3 3/4	3 3/4	5 5/8	
2	1	7 1/4	4 3/4	4 3/4	9 3/8	4 3/4	4 3/4	6 5/8	
3	1	8 1/4	5 3/4	5 3/4	10 3/8	5 3/4	5 3/4	7 5/8	
4	1	9 1/4	6 3/4	6 3/4	11 3/8	6 3/4	6 3/4	8 5/8	
5	1	10 3/8	7 7/8	7 7/8	12 1/2	7 7/8	7 7/8	9 3/4	
6	1	11 5/8	9 1/8	9 1/8	13 3/4	9 1/8	9 1/8	11	
7	1	12 3/4	10 1/4	10 1/4	14 7/8	10 1/4	10 1/4	12 1/8	
8	1	14 3/8	11 7/8	11 7/8	16 1/2	11 7/8	11 7/8	13 3/4	
9	1	15 1/8	12 5/8	12 5/8	17 1/4	12 5/8	12 5/8	14 1/2	
3	2	15 1/2	13	5 3/4	17 5/8	13	5 3/4	14 7/8	
4	2	17 1/2	15	6 3/4	19 5/8	15	6 3/4	16 7/8	
5	2	19 3/4	17 1/4	7 7/8	21 7/8	17 1/4	7 7/8	19 1/8	
6	2	22 1/4	19 3/4	9 1/8	24 3/8	19 3/4	9 1/8	21 5/8	
7	2	24 1/2	22	10 1/4	26 5/8	22	10 1/4	23 7/8	
8	2	27 3/4	25 1/4	11 7/8	29 7/8	25 1/4	11 7/8	27 1/8	
9	2	29 1/4	26 3/4	12 5/8	31 3/8	26 3/4	12 5/8	28 5/8	
6	3	32 7/8	30 3/8	9 1/8	35	30 3/8	9 1/8	32 1/4	
7	3	36 1/4	33 3/4	10 1/4	38 3/8	33 3/4	10 1/4	35 5/8	
8	3	41 1/8	38 5/8	11 7/8	43 1/4	38 5/8	11 7/8	40 1/2	
9	3	43 3/8	40 7/8	12 5/8	45 1/2	40 7/8	12 5/8	42 3/4	
7	4	48	45 1/2	10 1/4	50 1/8	45 1/2	10 1/4	47 3/8	
8	4	54 1/2	52	11 7/8	56 5/8	52	11 7/8	53 7/8	
9	4	57 1/2	55	12 5/8	59 5/8	55	12 5/8	56 7/8	
7	5	59 3/4	57 1/4	10 1/4	61 7/8	57 1/4	10 1/4	59 1/8	
8	5	67 7/8	65 3/8	11 7/8	70	65 3/8	11 7/8	67 1/4	
9	5	71 5/8	69 1/8	12 5/8	73 3/4	69 1/8	12 5/8	71	

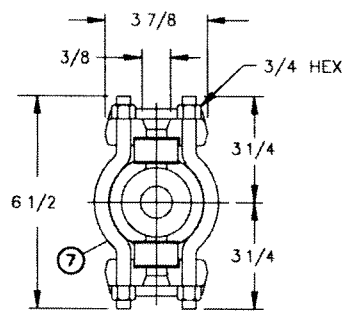
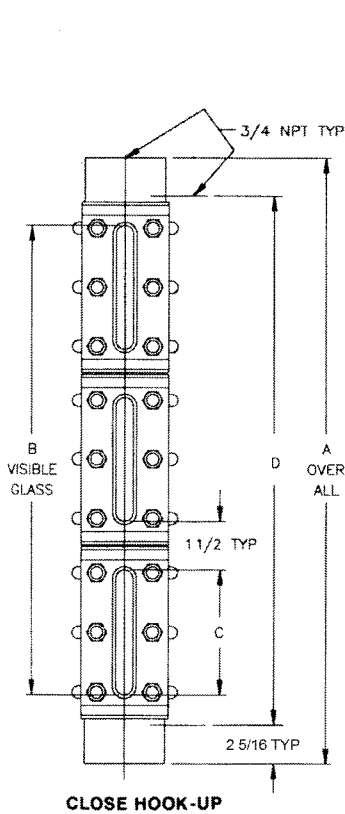

TRANSPARENT (STD. & CH)

ITEM NO.	NAME	MATERIAL
1	CHAMBER	ASTM A106 GRB
2	COVER	CARBON STEEL
3	GLASS	TEMPERED
4	GASKET	NON - ASBESTOS
5	CUSHION	NON - ASBESTOS
6	U-BOLT	ASTM A193 B7
7	BOLT	ASTM A193 B7
8	NUT	ASTM A194 2H

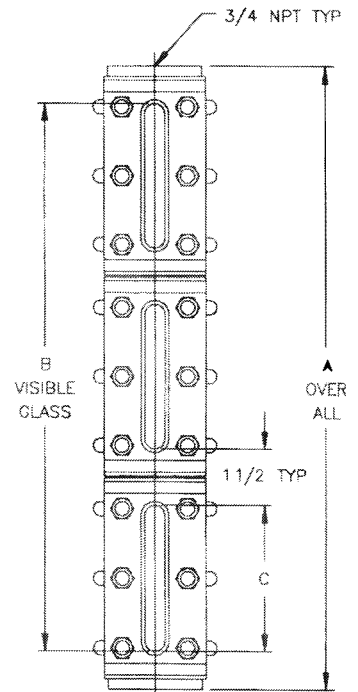

STANDARD

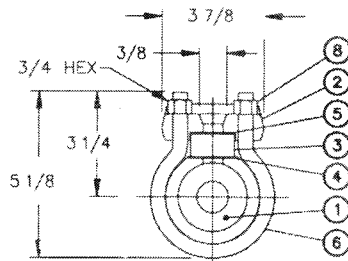

REFLEX (STD. & CH)

PRESSURES-TEMPERATURE RATINGS (psig)

REFLEX - LARGE CHAMBER							
GLASS SIZE	100° F	200° F	300° F	400° F	500° F	600° F	700° F
1	1020	990	950	910	850	755	620
2	980	950	915	875	815	725	600
3	940	910	880	840	780	695	590
4	900	870	840	805	750	665	560
5	860	830	800	770	715	635	540
6	830	805	775	745	690	610	530
7	790	765	735	710	660	585	510
8	750	725	700	670	625	555	500
9	695	695	670	645	600	530	480
TRANSPARENT - LARGE CHAMBER							
GLASS SIZE	100° F	200° F	300° F	400° F	500° F	600° F	700° F
1	790	765	740	705	660	585	390
2	750	725	700	670	625	555	380
3	720	695	670	645	600	530	360
4	680	655	635	610	565	500	340
5	650	630	605	580	540	480	330
6	610	590	570	545	510	450	310
7	580	560	540	520	485	430	300
8	540	520	505	480	450	400	280
9	500	485	465	445	415	370	260

SPECIALTY GAGES:

Heated/Cooled Externally

Example: 71 TL-HC (No. 7 glass, 1-section, Transparent, Low Pressure, Externally Heated/Cooled Gage)

Also available in close hook-up (CH) and internally heated/cooled type.



Glass-Trac Externally Heated/Cooled Gages may be either Low Pressure or Mid Pressure, Reflex or Transparent, and have $\frac{1}{2}$ + or $\frac{3}{4}$ + NPT Connections. Pressure-temperature ratings and sizes remain the same as standard flat gages.

On externally heated/cooled gages a metal tube is employed to transmit heating or cooling fluid. The tubing starts from an adaptor nut on one valve, passes along a machined groove in the gage body wall and connects to the adaptor nut in the opposite valve. Fluid piped through the tubing serves as the heating or cooling media. Gage bodies (liquid chambers) are made extra long to accommodate the groove and tubing.

Most common heating fluids are steam and hot water. To cool gages, methane, propane, freon and ammonia refrigerants are used.

The adaptor nut on the gage valves can be fitted with either a $\frac{1}{2}$ +NPT Female Tank connections or a $\frac{3}{4}$ +NPT Male Tank connection. Valve Types 1,2 and 4 may be used.

When ordering Glass-Trac Externally Heated/Cooled Gages, add HC to the gage size number.

Tank Connections (Also see pages 26 and 27)

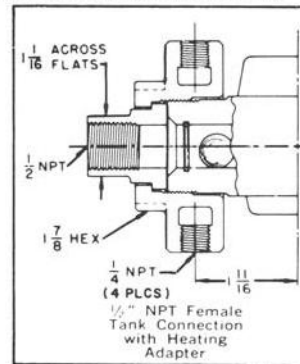

FIG. V

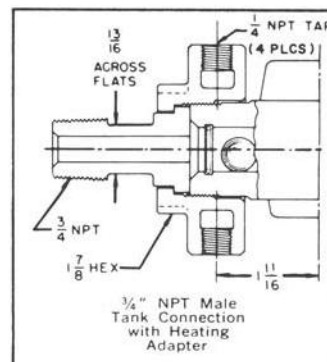
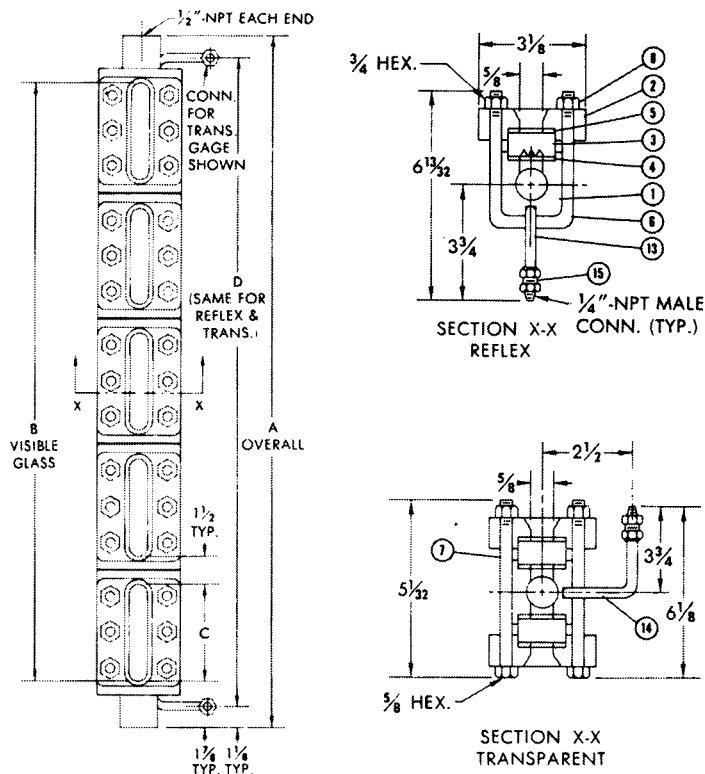

FIG. VI



PARTS

ITEM NO.	NAME	MATERIAL
1	CHAMBER	CARBON STEEL
2	COVER	CARBON STEEL
3	GLASS	TEMPERED
4	GASKET	NON-ASBESTOS
5	CUSHION	NON-ASBESTOS
6	U-BOLT	ASTM A193 B7
7	BOLT	ASTM A193 B7
8	NUT	ASTM A194 2H
13	TUBING	COPPER
14	TUBING	COPPER
15	FITTING	STEEL

DIMENSIONS AND PRESSURE RATINGS

SIZE NO.		DIMENSIONS (IN INCHES)				LOW PRESSURE				MID-PRESSURE			
GLASS SIZE	NO. SECT.	A	B	C	D	REFLEX MAX. PSIG @ TEMP.*		TRANSPARENT MAX. PSIG @ TEMP.*		REFLEX MAX. PSIG @ TEMP.*		TRANSPARENT MAX. PSIG @ TEMP.*	
						100° F	700° F	100° F	700° F	100° F	700° F	100° F	700° F
						1	1	7 1/2	3 3/4	3 3/4	5 1/4	2400	1520
2	1	8 1/2	4 3/4	4 3/4	6 1/4	2325	1470	1815	1150	2910	1840	2315	1470
3	1	9 1/2	5 3/4	5 3/4	7 1/4	2250	1420	1630	1050	2820	1780	2130	1340
4	1	10 1/2	6 3/4	6 3/4	8 1/4	2175	1370	1440	900	2725	1740	1940	1230
5	1	11 5/8	7 7/8	7 7/8	9 3/8	2100	1320	1250	790	2630	1660	1750	1100
6	1	12 7/8	9 1/8	9 1/8	10 5/8	2025	1280	1065	680	2535	1600	1565	990
7	1	14	10 1/4	10 1/4	11 3/4	1950	1230	875	550	2440	1540	1375	870
8	1	15 5/8	11 7/8	11 7/8	13 3/8	1875	1180	690	440	2345	1480	1190	750
9	1	16 3/8	12 5/8	12 5/8	14 1/8	1800	1140	500	320	2250	1420	1000	630
3	2	16 3/4	13	5 3/4	14 1/2	2250	1420	1630	1050	2820	1780	2130	1340
4	2	18 3/4	15	6 3/4	16 1/2	2175	1370	1440	900	2725	1740	1940	1230
5	2	21	17 1/4	7 7/8	18 3/4	2100	1320	1250	790	2630	1660	1750	1100
6	2	23 1/2	19 3/4	9 1/8	21 1/4	2025	1280	1065	680	2535	1600	1565	990
7	2	25 3/4	22	10 1/4	23 1/2	1950	1230	875	550	2440	1540	1375	870
8	2	29	25 1/4	11 7/8	26 3/4	1875	1180	690	440	2345	1480	1190	750
9	2	30 1/2	26 3/4	12 5/8	28 1/4	1800	1140	500	320	2250	1420	1000	630
6	3	34 1/8	30 3/8	9 1/8	31 7/8	2025	1280	1065	680	2535	1600	1565	990
7	3	37 1/2	33 3/4	10 1/4	35 1/4	1950	1230	875	550	2440	1540	1375	870
8	3	42 3/8	38 5/8	11 7/8	40 1/8	1875	1180	690	440	2345	1480	1190	750
9	3	44 5/8	40 7/8	12 5/8	42 3/8	1800	1140	500	320	2250	1420	1000	630
7	4	49 1/4	45 1/2	10 1/4	47	1950	1230	875	550	2440	1540	1375	870
8	4	55 3/4	52	11 7/8	53 1/2	1875	1180	690	440	2345	1480	1190	750
9	4	58 3/4	55	12 5/8	56 1/2	1800	1140	500	320	2250	1420	1000	630
7	5	61	57 1/4	10 1/4	58 3/4	1950	1230	875	550	2440	1540	1375	870
8	5	69 1/8	65 3/8	11 7/8	66 7/8	1875	1180	690	440	2345	1480	1190	750
9	5	72 7/8	69 1/8	12 5/8	70 5/8	1800	1140	500	320	2250	1420	1000	630

* Saturated steam to 350 WSP

**Maximum saturated steam 600 WSP with mica shields

SPECIALTY GAGE:

Frost-Prevention Extensions

Example: 81 RL-FP w/ 3⁵/₈+extensions (No.8 glass, 1-section, Reflex, Low Pressure, Frost Preventive Gage with 3⁵/₈+extensions).



Glass-Trac plastic extensions for flat gage glasses prevent frost from forming in the liquid level view slot in low temperature services. Reflex and Transparent Gages in all pressure ratings can be fitted with plastic extensions.

Projecting from the view slot, the clear plastic extensions keeps the liquid level indication clearly visible. Stocked extensions are 1⁵/₈+ and 3⁵/₈+ in length. If the gage is thickly insulated, longer extensions are available. The extension is held in place by stainless steel clamps fastened to the gage cover. For extra low temperature services, Glass-Trac gages can be made of special metals.

Recommended length for Frost Preventive Extensions: 1⁵/₈+ extension is standard from 80°F ambient to 0°F temperature. Add 1+ extension length for each 100° F below 0° F.

When ordering, specify length and add FP to gage size number.

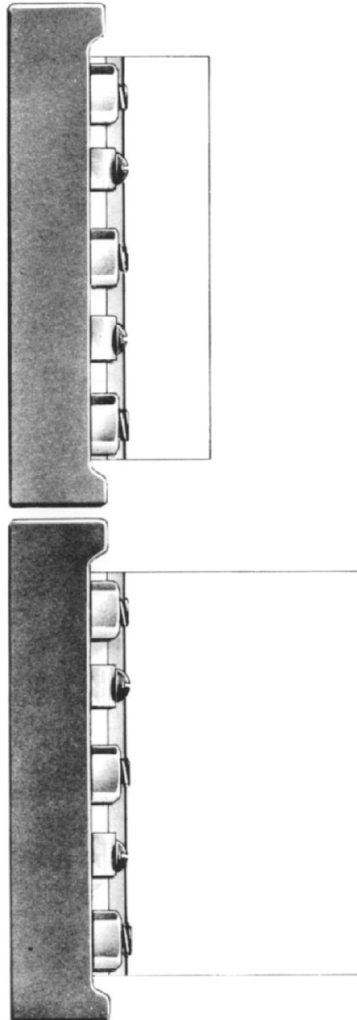

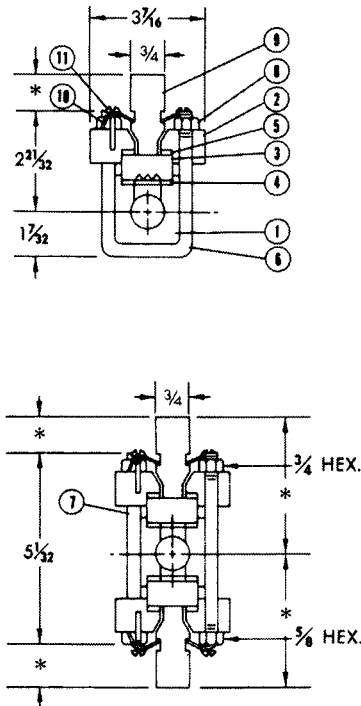
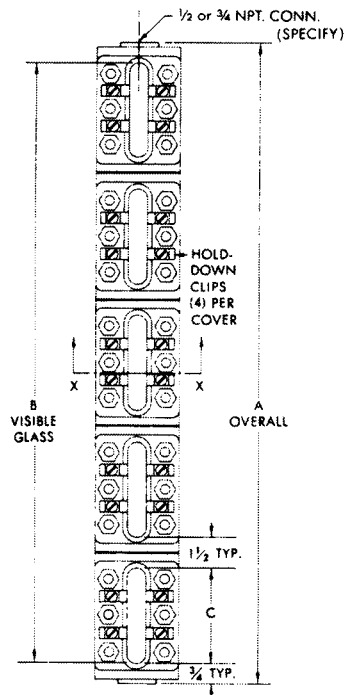

*Depends on Extension Length

PARTS

ITEM NO.	NAME	MATERIAL
1	CHAMBER	CARBON STEEL
2	COVER	CARBON STEEL
3	GLASS	TEMPERED
4	GASKET	NON-ASBESTOS
5	CUSHION	NON-ASBESTOS
6	U-BOLT	ASTM A193 B7
7	BOLT	ASTM A193 B7
8	NUT	ASTM A192 2H
9	EXTENSION	PLASTIC
10	CLIP	303 SS
11	SCREW	303 SS

DIMENSIONS AND PRESSURE RATINGS

SIZE NO.		DIMENSIONS (IN INCHES)			LOW PRESSURE				MID-PRESSURE			
GLASS SIZE	NO. SECT.	A	B	C	REFLEX MAX. PSIG @ TEMP.*		TRANSPARENT MAX. PSIG @ TEMP.*		REFLEX MAX. PSIG @ TEMP.*		TRANSPARENT MAX. PSIG @ TEMP.*	
					100° F	700° F	100° F	700° F	100° F	700° F	100° F	700° F
					1	1	5 1/4	3 3/4	3 3/4	2400	1520	2000
2	1	6 1/4	4 3/4	4 3/4	2325	1470	1815	1150	2910	1840	2315	1470
3	1	7 1/4	5 3/4	5 3/4	2250	1420	1630	1050	2820	1780	2130	1340
4	1	8 1/4	6 3/4	6 3/4	2175	1370	1440	900	2725	1740	1940	1230
5	1	9 3/8	7 7/8	7 7/8	2100	1320	1250	790	2630	1660	1750	1100
6	1	10 5/8	9 1/8	9 1/8	2025	1280	1065	680	2535	1600	1565	990
7	1	11 3/4	10 1/4	10 1/4	1950	1230	875	550	2440	1540	1375	870
8	1	13 3/8	11 7/8	11 7/8	1875	1180	690	440	2345	1480	1190	750
9	1	14 1/8	12 5/8	12 5/8	1800	1140	500	320	2250	1420	1000	630
3	2	14 1/2	13	5 3/4	2250	1420	1630	1050	2820	1780	2130	1340
4	2	16 1/2	15	6 3/4	2175	1370	1440	900	2725	1740	1940	1230
5	2	18 3/4	17 1/4	7 7/8	2100	1320	1250	790	2630	1660	1750	1100
6	2	21 1/4	19 3/4	9 1/8	2025	1280	1065	680	2535	1600	1565	990
7	2	23 1/2	22	10 1/4	1950	1230	875	550	2440	1540	1375	870
8	2	26 3/4	25 1/4	11 7/8	1875	1180	690	440	2345	1480	1190	750
9	2	28 1/4	26 3/4	12 5/8	1800	1140	500	320	2250	1420	1000	630
6	3	31 7/8	30 3/8	9 1/8	2025	1280	1065	680	2535	1600	1565	990
7	3	35 1/4	33 3/4	10 1/4	1950	1230	875	550	2440	1540	1375	870
8	3	40 1/8	38 5/8	11 7/8	1875	1180	690	440	2345	1480	1190	750
9	3	42 3/8	40 7/8	12 5/8	1800	1140	500	320	2250	1420	1000	630
7	4	47	45 1/2	10 1/4	1950	1230	875	550	2440	1540	1375	870
8	4	53 1/2	52	11 7/8	1875	1180	690	440	2345	1480	1190	750
9	4	56 1/2	55	12 5/8	1800	1140	500	320	2250	1420	1000	630
7	5	58 3/4	57 1/4	10 1/4	1950	1230	875	550	2440	1540	1375	870
8	5	66 7/8	65 3/8	11 7/8	1875	1180	690	440	2345	1480	1190	750
9	5	70 5/8	69 1/8	12 5/8	1800	1140	500	320	2250	1420	1000	630

*Saturated steam to 300 WSP

**Maximum saturated steam 600 WSP with mica shields

GAGE ACCESSORY: Illuminators (Explosion-Proof)

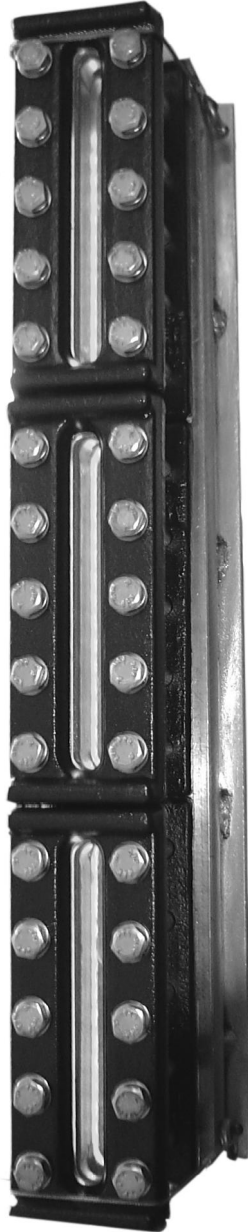

The Quest-Tec Solutions *See-Level™* LED Illuminator for hazardous locations utilizes the latest technology to provide brilliant green back lighting to any process gage. Innovative circuitry allows for the use of an individual light source every 1/2" along the length of any gage. With a life span of over 100,000 hours each, light source is likely to never need replacing. Even in the event of an individual lamp failure, the design provides lighting overlap ensuring that the fluid level is always illuminated. All of this is accomplished with a meager 5 watts of power usage.

Through the use of new attachment techniques, the *See-Level™* Illuminator readily mounts to any brand of existing or new process gages in a matter of minutes without the loosening of any cover bolting. Mounting requires no special tools or modifications to the existing structure. Set it up, attach the power and go! It's that easy.

The modular design allows for a single illuminator to be manufactured to your specific visible length eliminating the labor involved in mounting and wiring multiple illuminators.

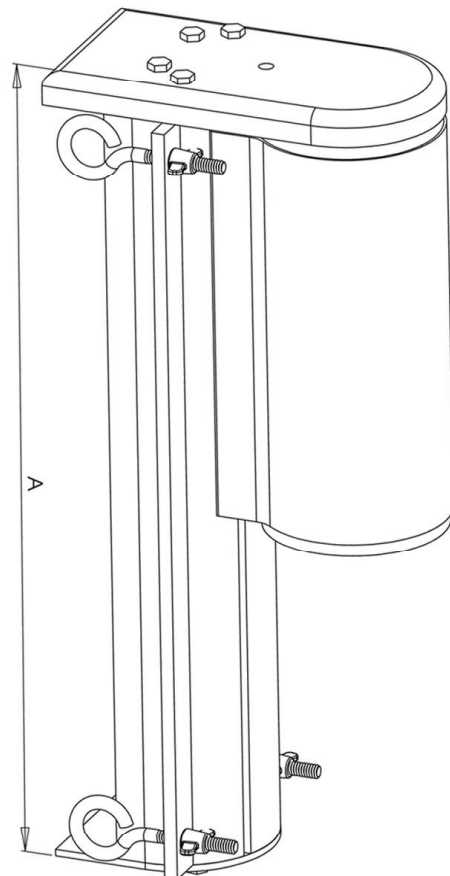

DIMENSIONAL DATA

Flat Gage Glasses

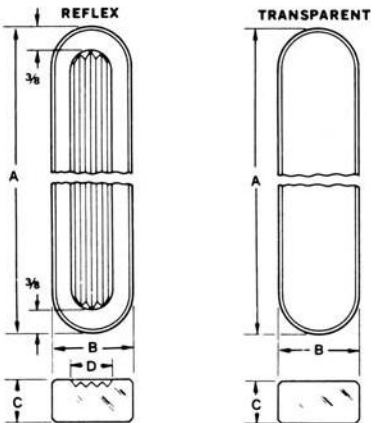

GLASS SIZE NO.	A
1	4 1/2"
2	5 1/2"
3	6 1/2"
4	7 1/2"
5	8 5/8"
6	9 7/8"
7	11"
8	12 5/8"
9	13 3/8"

B	C	D
1 5/16"	11/16"	11/16"

TOLERANCE FOR DIMENSIONS ABOVE

A	B	C
+0	+1/32"	+0
-1/32"	-0	1/32"

Glass-Trac standard gage glass is made of borosilicate glass. For higher temperature service or requirements, aluminosilicate glass can be supplied.

Mica shields are available for use with Transparent Gages in steam boiler service enabling glass to be used in higher pressures. They are placed between gasket and glass. KEL-F® shields are available for use with Transparent Gages in corrosive service.

NOTE: For cyclic temperature applications, or to aid in torque retention, spring washers are available upon request.

LIQUID LEVEL GAGE VOLUMES

STANDARD GAGE VOLUMES (APPROXIMATE)						LARGE CHAMBER GAGE VOLUMES (APPROXIMATE)			
GLASS SIZE NO.	VISIBLE LENGTH (INCHES)	REFLEX		TRANSPARENT		REFLEX		TRANSPARENT	
		CU. IN.	CU. CM.	CU. IN.	CU. CM.	CU. IN.	CU. CM.	CU. IN.	CU. CM.
1	3 3/4	2.07	34	3.17	52	15.49	254	15.92	261
2	4 3/4	2.61	43	3.99	65	19.16	314	19.70	323
3	5 3/4	3.21	53	4.82	79	22.82	374	23.48	385
4	6 3/4	3.68	60	5.63	92	26.49	434	27.26	447
5	7 7/8	4.28	70	6.55	107	30.61	501	31.51	516
6	9 1/8	4.94	81	7.58	124	35.19	577	36.24	594
7	10 1/4	5.55	91	8.50	139	39.31	644	40.49	664
8	11 7/8	6.42	105	9.83	161	45.26	742	46.64	764
9	12 5/8	6.82	112	10.45	171	48.01	787	49.47	811

NOTE: For multiple section level gages, add $\delta C \delta$ volume for each additional section. $\delta C \delta$ is volume between gage sections.

QUICK-OPENING LEVERS

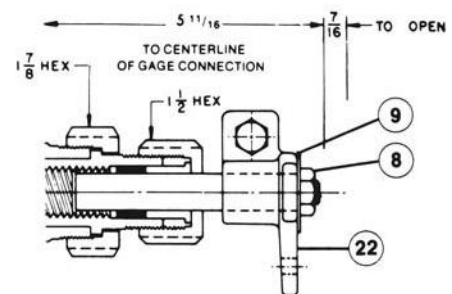
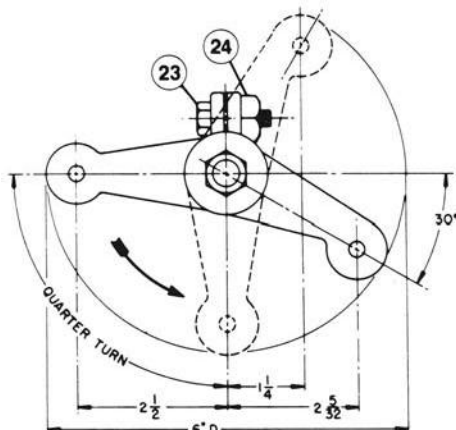
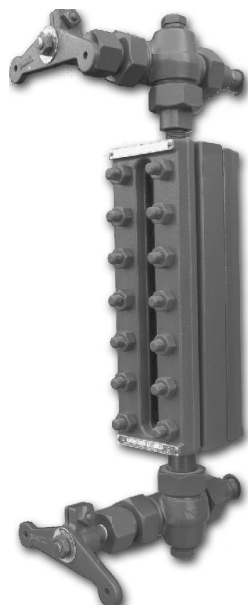

PARTS

ITEM NO.	PART	MATERIAL
8	STEM NUT	CARBON STEEL
9	NAME PLATE	304 SS
22	LEVER	DUCTILE IRON
23	BOLT	CARBON STEEL
24	NUT	CARBON STEEL

GAGE CONNECTIONS

Glass-Trac gage valves, types 1 thru 7, can be fitted with any gage connection shown here.

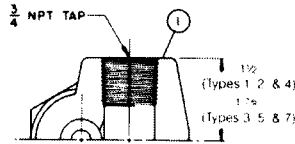

FIG. VII

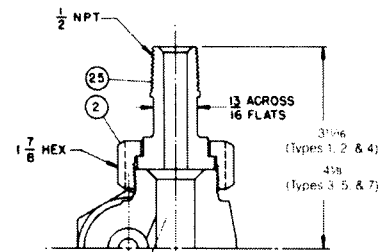

FIG. VIII

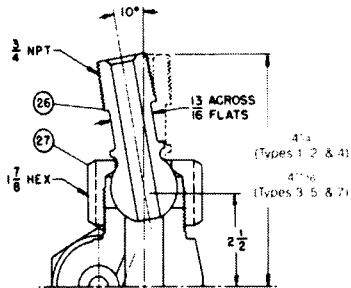

FIG. X

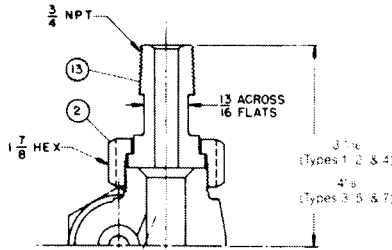

FIG. XI

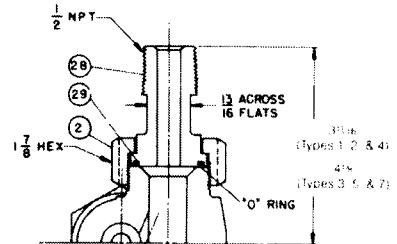

FIG. XIII

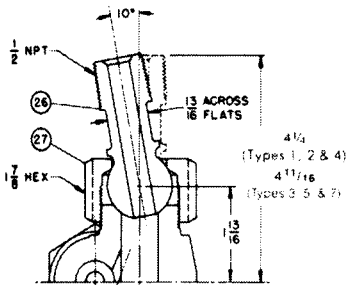

FIG. XIV

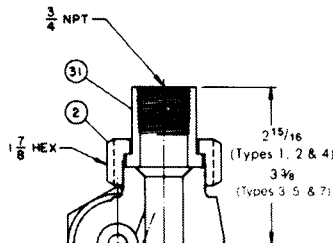

FIG. XV

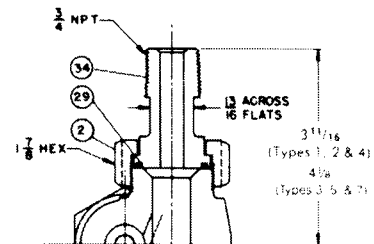

FIG. XVI

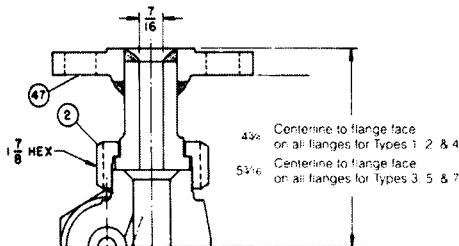

FIG. XVII

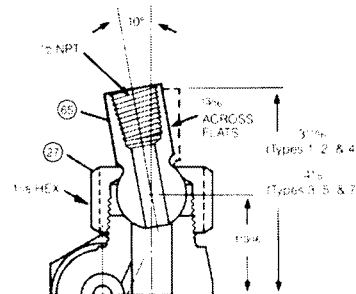

FIG. XXIX

PARTS

ITEM NO.	NAME	STANDARD	316 SS WETTED PARTS
		MATERIAL	MATERIAL
1	BODY	FORGED STEEL	316 SS
2	UNION NUT	CARBON STEEL	CARBON STEEL
25	MALE CONNECTOR - 1/2"	CARBON STEEL	316 SS
26	MALE SPHERICAL CONN. - 3/4"	CARBON STEEL	316 SS
26	MALE SPHERICAL CONN. - 1/2"	CARBON STEEL	316 SS
27	SPHERICAL NUT	CARBON STEEL	CARBON STEEL
28	MALE "O" RING CONN. - 1/2"	CARBON STEEL	316 SS
*29	"O" RING	BUNA-N	BUNA-NN
31	FEMALE UNION - 3/4"	ALLOY STEEL	-
34	MALE "O" RING CONN. - 3/4"	CARBON STEEL	316 SS
47	ANSI RF SLIP-ON FLG'D ASSY.	CARBON STEEL	316 SS
**65	FEMALE SPER. CONN. - 1/2"	CARBON STEEL	316 SS

*O-Ring of Teflon® or Viton® on request.

**3/4" NPT female spherical connections are not available.

Note: Valve shown is for bottom left hand (or top right hand) location. Opposite hand is reversed. Valve are furnished in pairs of one bottom left hand and one top left hand.

TANK CONNECTIONS

All Tank Connections for Glass-Trac Gage Valves are shown here including the standard connections illustrated on the valves. For Types 1, 2 and 4 Valves, Fig. II through XXVII are available.

For Types 3, 5, and 7 Valves, Fig. XXV through Fig. XXVIII are available.

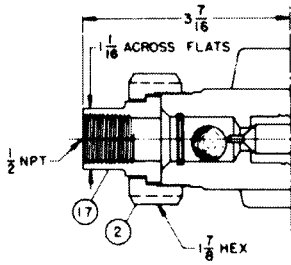

FIG. II

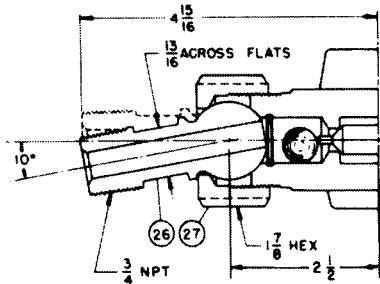

FIG. III

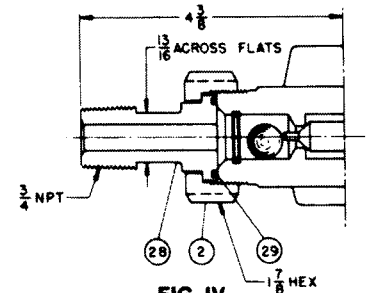

FIG. IV

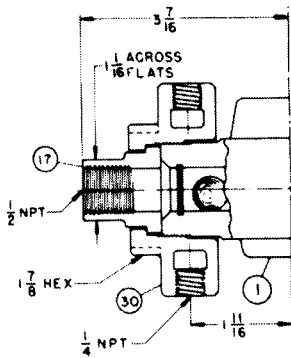

FIG. V

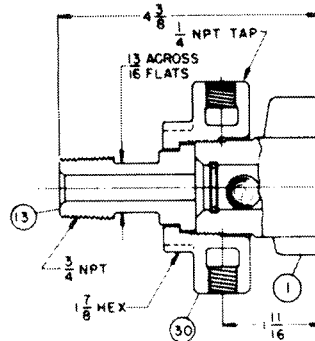

FIG. VI

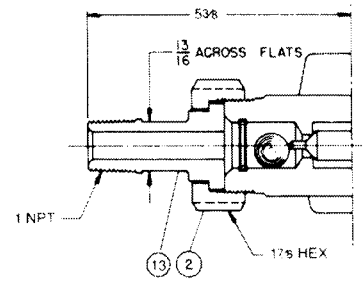

FIG. VII

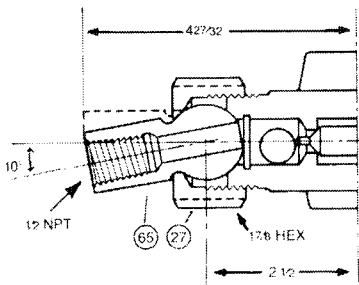

FIG. XVIII

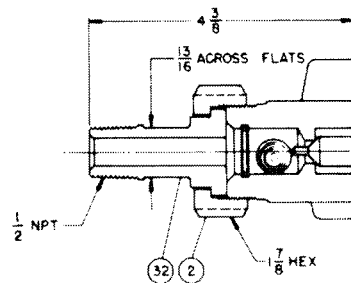

FIG. XIX

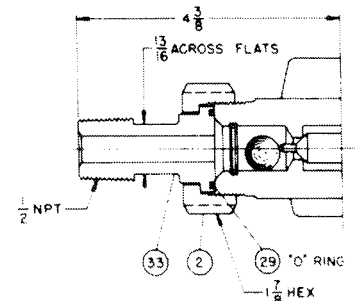

FIG. XX

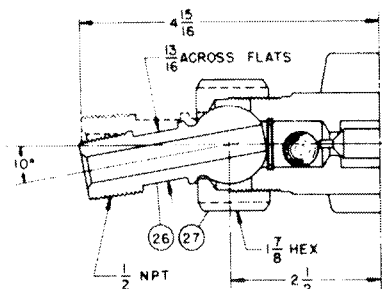

FIG. XXI

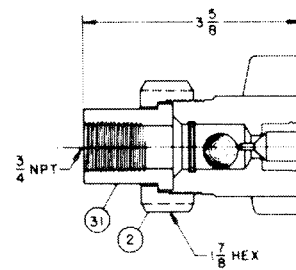

FIG. XXII

TANK CONNECTIONS (CONTINUED)

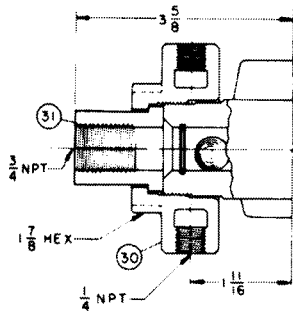

FIG. XXIII

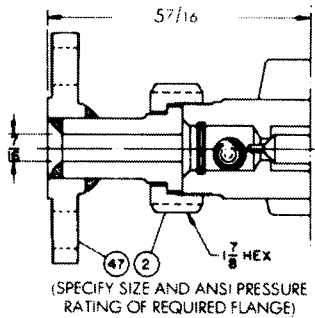

FIG. XXIV

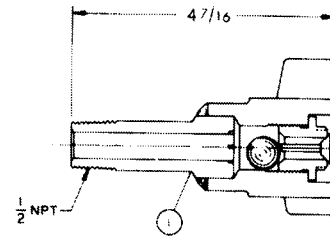

FIG. XXV

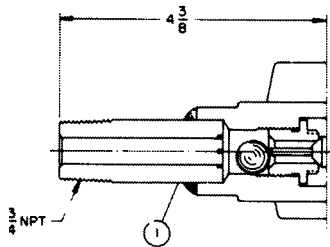

FIG. XXVI

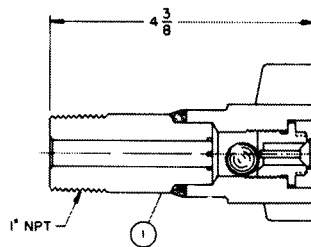

FIG. XXVII

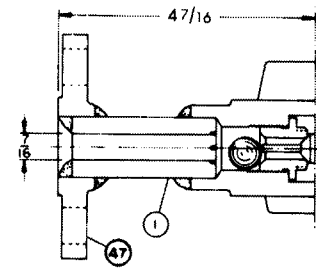

FIG. XXVIII

PARTS

ITEM NO	NAME	STANDARD	316 SS WETTED PARTS
		MATERIAL	MATERIAL
1	BODY	FORGED STEEL	316 SS
1	BODY - 1/2" NPT SHANK	FORGED STEEL	316 SS
1	BODY - 3/4" NPT SHANK	FORGED STEEL	316 SS
1	BODY - 1" NPT SHANK	FORGED STEEL	316 SS
1	BODY - RF FLG'D SHANK	FORGED STEEL	316 SS
2	UNION NUT	CARBON STEEL	CARBON STEEL
*13	MALE CONNECTOR	CARBON STEEL	316 SS
17	FEMALE CONNECTOR - 1/2"	CARBON STEEL	316 SS
26	MALE SPHERICAL CONN.	CARBON STEEL	316 SS
27	SPHERICAL NUT	CARBON STEEL	CARBON STEEL
*28	MALE "O" RING CONN. - 3/4"	CARBON STEEL	316 SS
**29	"O" RING	BUNA-N	BUNA-N
30	HEATED/COOLED NUT	CARBON STEEL	CARBON STEEL
31	FEMALE CONNECTION - 3/4"	ALLOY STEEL	-
*32	MALE CONNECTOR - 1/2"	CARBON STEEL	316 SS
*33	MALE "O" RING CONN. - 1/2"	CARBON STEEL	316 SS
47	ANSI RF SLIP-ONFLG'D ASSY.	CARBON STEEL	316 SS
***65	FEMALE SPHER. CONN. - 1/2"	CARBON STEEL	316 SS

* Has floating tailpiece for ± 1/8" maximum misalignment on the overall center-to-center.

**O-Ring of Teflon® or Viton® on request.

***3/4" NPT female connection is not available.

Note: Valve is for bottom left hand (or top right hand) location. Opposite hand is reversed. Valves are furnished in pairs of one bottom left hand and one top left hand.

Viton® is a registered trademark of DuPont.

INSTALLATION: STANDARD GAGES

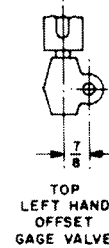
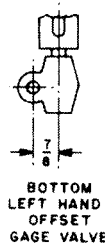
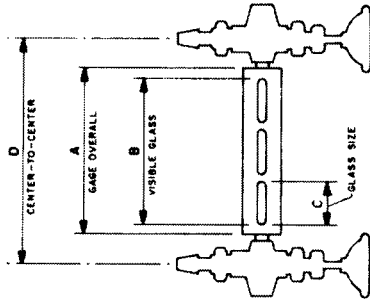

NOTE: A. B. C. D Dimensions are in inches

SIZE NO.		A GAGE OVERALL	B VISIBLE GLASS	C VISIBLE GLASS	D* MINIMUM VALVE CENTER-TO-CENTER WITH GAGE CONNECTION							
					FOR GAGES TAPPED 1/2" NPT				FOR GAGES TAPPED 3/4" NPT			
					GLASS NO.	NO. SECT.	** 1/2"- NPT FEMALE SCREWED CAT. 1S, 2S, 4S	** 1/2"- NPT FEMALE SCREWED CAT. 1U, 2U, 4U	1/2"-NPT MALE UNION FIG. VIII	1/2"-NPT MALE SPHERICAL FIG. XIV	**3/4"-NPT FEMALE SCREWED CAT. 1S, 2S, 4S	3/4"-NPT FEMALE SCREWED CAT. 1U, 2U, 4U
1	1	5 1/4	3 3/4	3 3/4	8 1/2	11	11 5/8	12 3/4	8 3/4	11 5/8	11 1/2	12 5/8
2	1	6 1/4	4 3/4	4 3/4	9 1/2	12	12 5/8	13 3/4	9 3/4	12 5/8	12 1/2	13 5/8
3	1	7 1/4	5 3/4	5 3/4	10 1/2	13	13 5/8	14 3/4	10 3/4	13 5/8	13 1/2	14 5/8
4	1	8 1/4	6 3/4	6 3/4	11 1/2	14	14 5/8	15 3/4	11 3/4	14 5/8	14 1/2	15 5/8
5	1	9 3/8	7 7/8	7 7/8	12 5/8	15 1/8	15 3/4	16 7/8	12 7/8	15 3/4	15 5/8	16 3/4
6	1	10 5/8	9 1/8	9 1/8	13 7/8	16 3/8	17	18 1/8	14 1/8	17	16 7/8	18
7	1	11 3/4	10 1/4	10 1/4	15	17 1/2	18 1/8	19 1/4	15 1/4	18 1/8	18	19 1/8
8	1	13 3/8	11 7/8	11 7/8	16 5/8	19 1/8	19 3/4	20 7/8	16 7/8	19 3/4	19 5/8	20 3/4
9	1	14 1/8	12 5/8	12 5/8	17 3/8	19 7/8	20 1/2	21 5/8	17 5/8	20 1/2	20 3/8	21 1/2
3	2	14 1/2	13	5 3/4	17 3/4	20 1/4	20 7/8	22	18	20 7/8	20 3/4	21 7/8
4	2	16 1/2	15	6 3/4	19 3/4	22 1/4	22 7/8	24	20	22 7/8	22 3/4	23 7/8
5	2	18 3/4	17 1/4	7 7/8	22	24 1/2	25 1/8	26 1/4	22 1/4	25 1/8	25	26 1/8
6	2	21 1/4	19 3/4	9 1/8	24 1/2	27	27 5/8	28 3/4	24 3/4	27 5/8	27 1/2	28 5/8
7	2	23 1/2	22	10 1/4	26 3/4	29 1/4	29 7/8	31	27	29 7/8	29 3/4	30 7/8
8	2	26 3/4	25 1/4	11 7/8	30	32 1/2	33 1/8	34 1/4	30 1/4	33 1/8	33	34 1/8
9	2	28 1/4	26 3/4	12 5/8	31 1/2	34	34 5/8	35 3/4	31 3/4	34 5/8	34 1/2	35 5/8
6	3	31 7/8	30 3/8	9 1/8	35 1/8	37 5/8	38 1/4	39 3/8	35 5/8	38 1/4	38 1/8	39 1/4
7	3	35 1/4	33 3/4	10 1/4	38 1/2	41	41 5/8	42 3/4	38 3/4	41 5/8	41 1/2	42 5/8
8	3	40 1/8	38 5/8	11 7/8	43 3/8	45 7/8	46 1/2	47 5/8	43 5/8	46 1/2	46 3/8	47 1/2
9	3	42 3/8	40 7/8	12 5/8	45 5/8	48 1/8	48 3/4	49 7/8	45 7/8	48 3/4	48 5/8	49 3/4
7	4	47	45 1/2	10 1/4	50 1/4	52 3/4	53 3/8	54 1/2	50 1/2	53 5/8	53 1/4	54 3/8
8	4	53 1/2	52	11 7/8	56 3/4	59 1/4	59 7/8	61	57	59 7/8	59 3/4	60 7/8
9	4	56 1/2	55	12 5/8	59 3/4	62 1/4	62 7/8	64	60	62 7/8	62 3/4	63 7/8
7	5	58 3/4	57 1/4	10 1/4	62	64 1/2	65 1/8	66 1/4	62 1/4	65 1/8	65	66 1/8
8	5	66 7/8	65 3/8	11 7/8	70 1/8	72 5/8	73 1/4	74 3/8	70 3/8	73 1/4	73 1/8	74 1/4
9	5	70 5/8	69 1/8	12 5/8	73 7/8	76 3/8	77	78 1/8	74 1/8	77	76 7/8	78
8	6	80 1/4	78 3/4	11 7/8	83 1/2	86	86 5/8	87 3/4	83 3/4	86 5/8	86 1/2	87 5/8
9	6	84 3/4	83 1/4	12 5/8	88	90 1/2	91 1/8	92 1/4	88 1/4	91 1/8	91	92 1/8
8	7	93 5/8	92 1/8	11 7/8	96 7/8	99 3/8	100	101 1/8	97 1/8	100	99 7/8	101
9	7	98 7/8	97 3/8	12 5/8	102 1/8	104 5/8	105 1/4	106 3/8	102 3/8	105 1/4	105 1/8	106 1/4
8	8	107	105 1/2	11 7/8	110 1/4	112 3/4	113 3/8	114 1/2	110 1/2	113 3/8	113 1/4	114 3/8
9	8	113	111 1/2	12 5/8	116 1/4	118 3/4	119 3/8	120 1/2	116 1/2	119 3/8	119 1/4	120 3/8
8	9	120 3/8	118 7/8	11 7/8	123 5/8	126 1/8	126 3/4	127 7/8	123 7/8	126 3/4	126 5/8	127 3/4
9	9	127 1/8	125 5/8	12 5/8	130 3/8	132 7/8	133 1/2	134 5/8	130 5/8	133 1/2	133 3/8	134 1/2

*Dimensions in column "D" apply to low-pressure (series "L"), mid-pressure (series "M"), 1/2" NPT high-pressure (series "H"), frost-free (all series), and internally heated/cooled reflex and transparent level gages tapped 1/2" NPT or 3/4" NPT. For installation dimensions on other level gages see footnote.

**These dimensions use close pipe nipples. For short 1/2" nipple add 3/4"; for short 3/4" nipple add 11/4".

Note: Use the following constants for other level gages.

1. Low pressure (series "L") large chamber, add 1" to above "A" and "D" dimensions.
2. Low-pressure (series "L"), mid-pressure (series "M") externally heated/cooled, add 2 1/4" to above "D" dimensions.
3. For valve Types 3, 5, or 7, add 7/8" to Column "D" to obtain minimum centers.
4. For High Pressure (series "H") with 3/4" NPT, add 1 1/2" to dimensions "A" and "D".
5. For a 1/2" NPT Female Spherical Gage connection (Figure XXIX), add 1/4".

INSTALLATION: CLOSE HOOK-UP GAGES (GAGE CONNECTIONS)

SIZE NO.	MINIMUM CENTER-TO-CENTER TANK CONNECTIONS					
	STRAIGHT-THRU 1/2" VALVE 3/4"		OFFSET VALVE HANDLES 1/2" INSIDE 3/4"		OFFSET VALVE HANDLES 1/2" OUTSIDE 3/4"	
11	5 1/4"	5 5/8"	3 1/2"	3 7/8"	7"	7 3/8"
21	6 1/4"	6 5/8"	4 1/2"	4 7/8"	8"	8 3/8"
31	7 1/4"	7 5/8"	5 1/2"	5 7/8"	9"	9 3/8"
41	8 1/4"	8 5/8"	6 1/2"	6 7/8"	10"	10 3/8"
51	9 3/8"	9 3/4"	7 5/8"	8"	11 1/8"	11 1/2"
61	10 5/8"	11"	8 7/8"	9 1/4"	12 3/8"	12 3/4"
71	11 3/4"	12 1/8"	10"	10 3/8"	13 1/2"	13 7/8"
81	13 3/8"	13 3/4"	11 5/8"	12"	15 1/8"	15 1/2"
91	14 1/8"	14 1/2"	12 3/8"	12 3/4"	15 7/8"	16 1/4"
32	14 1/2"	14 7/8"	12 3/4"	13 1/8"	16 1/4"	16 5/8"
42	16 1/2"	16 7/8"	14 3/4"	15 1/8"	18 1/4"	18 5/8"
52	18 3/4"	19 1/8"	17"	17 3/8"	20 1/2"	20 7/8"
62	21 1/4"	21 5/8"	19 1/2"	19 7/8"	23"	23 3/8"
72	23 1/2"	23 7/8"	21 3/4"	22 1/8"	25 1/4"	25 5/8"
82	26 3/4"	27 1/8"	25"	25 3/8"	28 1/2"	28 7/8"
92	28 1/4"	28 5/8"	26 1/2"	26 7/8"	30"	30 3/8"
63	31 7/8"	32 1/4"	30 1/8"	30 1/2"	33 5/8"	34"
73	35 1/4"	35 5/8"	33 1/2"	33 7/8"	37"	37 3/8"
83	40 1/8"	40 1/2"	38 3/8"	38 3/4"	41 7/8"	42 1/4"
93	42 3/8"	42 3/4"	40 5/8"	41"	44 1/8"	44 1/2"
74	47"	47 3/8"	45 1/4"	45 5/8"	48 3/4"	49 1/8"
84	53 1/2"	53 7/8"	51 3/4"	52 1/8"	55 1/4"	55 5/8"
94	56 1/2"	56 7/8"	54 3/4"	55 1/8"	58 1/4"	58 5/8"
75	58 3/4"	59 1/8"	57"	57 3/8"	60 1/2"	60 7/8"
85	66 7/8"	67 1/4"	65 1/8"	65 1/2"	68 5/8"	69"
95	70 5/8"	71"	68 7/8"	69 1/8"	72 3/8"	72 3/4"
86	80 1/4"	80 5/8"	78 1/2"	78 7/8"	82"	82 3/8"
96	84 3/4"	85 1/8"	83"	83 3/8"	86 1/2"	86 7/8"
87	93 5/8"	94"	91 7/8"	92 1/4"	95 3/8"	95 3/4"
97	98 7/8"	99 1/4"	97 1/8"	97 1/2"	100 5/8"	101"
88	107"	107 3/8"	105 1/4"	105 5/8"	108 3/4"	109 1/8"
98	113"	113 3/8"	111 1/4"	111 5/8"	114 3/4"	115 1/8"
89	120 3/8"	120 3/4"	118 5/8"	119"	122 1/8"	122 1/2"
99	127 1/8"	127 1/2"	125 3/8"	125 3/4"	128 7/8"	129 1/4"

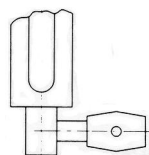

STRAIGHT-THRU VALVE

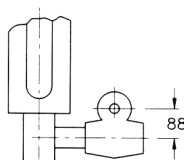

CLOSE HOOK-UP WITH HANDLE INSIDE

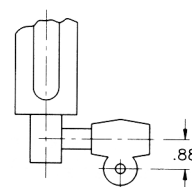

CLOSE HOOK-UP WITH HANDLE OUTSIDE

CAUTION

Gage glasses may fail from improper external mechanical stress or accident rather than from internal pressure, but both factors should be considered. Four basic precautions when heeded will assure the gage glass user of safe, satisfactory performance:

1. Proper glass selection
2. Correct installation.
3. Periodic inspection and cleaning.
4. Replacement as necessary.

Proper glass selection involves size, pressure rating and quality of glass. Flat and tubular glasses should fit perfectly without stress; glass should be crystal clear and without blemish; length determines pressure rating; if longer glass results in breakage, a multiple-section gage with shorter glasses should be considered. Installation involves proper seating on gaskets and cushions; glass-to-metal contact should not occur; do not install any glass with scratches or chipped edges; do not tighten gage bolts when gage is in use; use torque instructions provided

with gage; use gage valves with ball checks that shut-off automatically if breakage occurs; make sure vessel center-to-centers are correct and vertical. Proper tightening of bolts with torque wrench is extremely important, so that no unusual stress is introduced into the glass.

Clean outside of glasses with ordinary glass cleaners, not harsh chemicals; check for scratches, chipped edges on glass; inspect glass for clarity.

Glass should be replaced if any blemish mars surface. If gage is taken apart, glass, gaskets and cushions should be automatically replaced to reduce risk; make sure gage or tubular valves surfaces are clean and dry before installing glasses.

For safety purposes, glasses in high temperature service should be replaced more often than similar glasses used in low temperature services.

GLASS-TRAC GAGE ASSEMBLY

(Numbers Indicate Proper Bolt Torquing Sequence.)

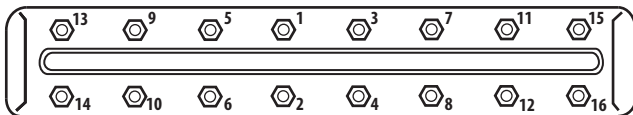

Gage Series	Torque (Tighten in 4-5 Ft.-Lb. Steps)
Low Press. Large Chamber	20 Ft.-Lb.
Mid-Press	32 Ft.-Lb.
High-Press	40 FT.-Lb.