

## 1/2" Heavy Duty Hydraulic Regulator

**Series 20313**

### Features

- ▶ Original Shear-Seal® technology
- ▶ Self adjusting
- ▶ High flow capacity
- ▶ Tolerates contaminated media
- ▶ Fail-safe motor control options

### Applications

- ▶ BOP Control Units
- ▶ Coiled tube reels
- ▶ Oil and gas systems
- ▶ Pressure sensitive applications



### General Specifications\*

<b>Pressure:</b> Supply/Inlet Pressure: 5,000 psi (345 bar)  Regulated Pressure Range: High Sensitivity 300 - 1600 psi (21 -110 bar) Full Range 300 - 3000 psi (21 - 207 bar)  Regulated Pressure Range "F" Prefix Pneumatic failsafe motor: High Sensitivity 300 - 1600 psi (21 -110 bar) Full Range 300 - 3000 psi (21 - 207 bar)  Regulated Pressure Range "G" Prefix Hydraulic failsafe motor: High Sensitivity 300 - 1600 psi (21 -110 bar) Full Range 300 - 3000 psi (21 - 207 bar)  Fluid Temperature Range: -40° to +250°F (-40° to +121° C)  Proof Pressure: 7,500 psi (517 bar)	<b>Materials of Construction:</b> Body: Stainless Steel (standard)  Flanges: Carbon Steel (standard) Option: Stainless steel  Spring Tower Housing: Manual: Phosphate coated alloy steel (std.) Pneumatic Motor model: Phosphate coated alloy steel (std.) Hydraulic Motor model: Phosphate coated alloy steel (std.) Option: Stainless Steel  Standard O'ring Material: Buna N  Socket Head Screws: Zinc plated alloy steel (standard) Option: Stainless steel  Wetted Parts: Stainless steel & bronze
<b>Flow:</b> Flow Rate: 45 GPM (@ 50/ft/s)  Cv Inlet: 6.7  Cv Vent: 6.7	<b>Pneumatic Pilot Motor ("F" prefix):</b> Pilot Motor Working Pressure: 80 - 120 psi (5.5 - 8.3 bar)  Porting: 1/4" NPT  Operating Temperature Range: 32° to +250°F (0° to +120°C)
<b>Porting:</b> Inlet: 1/2" NPT Standard, SAE Option  Outlet: 1/2" NPT Standard, SAE Option  Vent: 1/2" NPT Standard, SAE Option  Bleed Port: 1/4" Dia. hole	<b>Hydraulic Pilot Motor ("G" prefix):</b> Pilot Motor Working Pressure: 400 - 1600 PSI (6.9 - 110 bar)  Porting: SAE for 3/8" Tube (Size -6)  Operating Temperature Range: -40° to +250°F (-40° to +121°C)
	<b>Approximate Shipping Weight:</b> Manual: 21 lbs. (9.5 kg)  Pneumatic or Hydraulic Motor: 44 lbs. (20.0 kg)

\* See product configurator for additional options.

# 1/2" Heavy Duty Hydraulic Regulator

**Series 20313**

## Technical Drawings

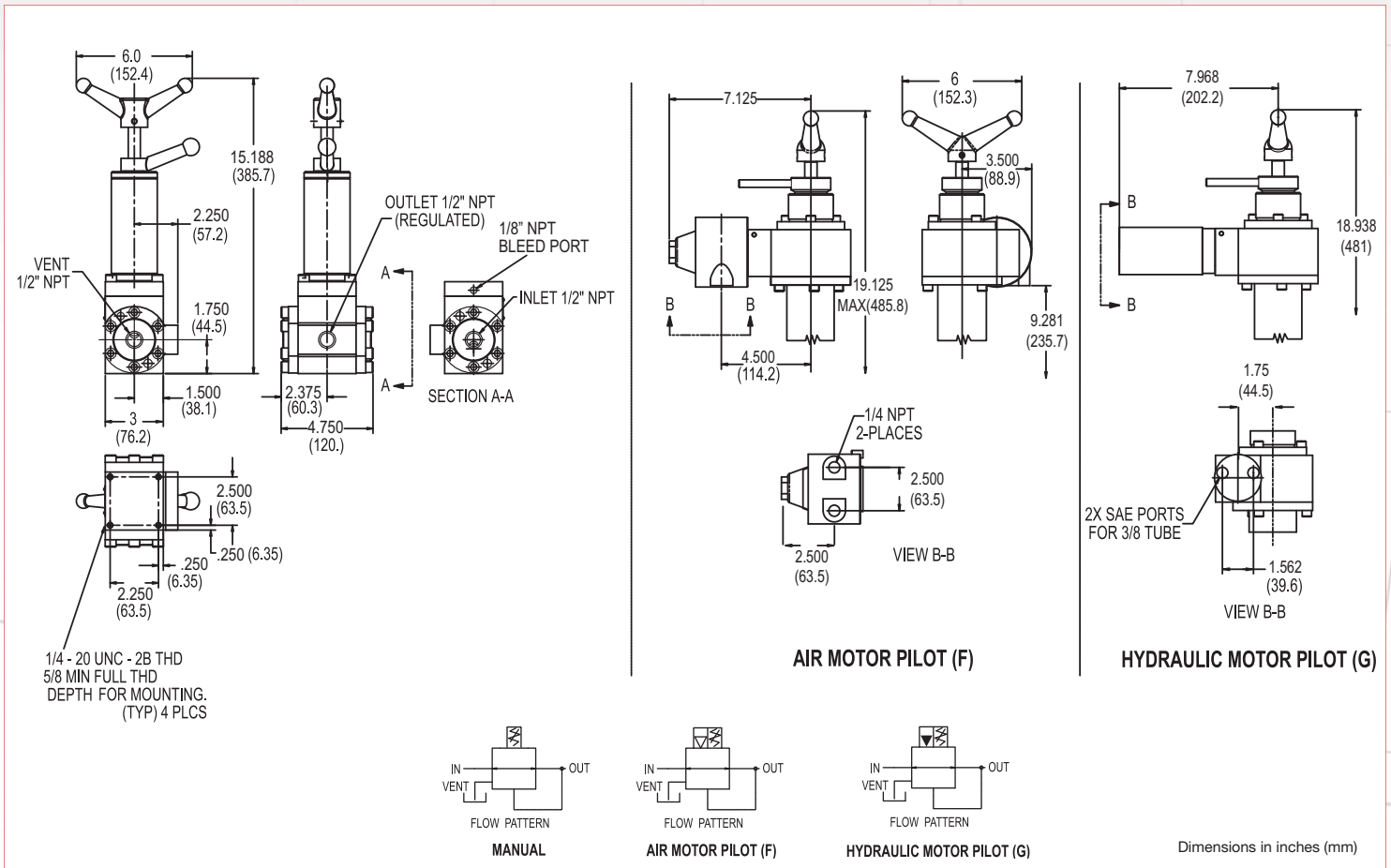

## Product Configurator

Example: **20313S6WQ2**

### Adjustment Method

Blank	Manual
F	Pneumatic motor
G	Hydraulic motor

### Series

20313S6WQ2 1/2" Shear-Seal Regulator

### Option

Blank	NPT porting
-MS	SAE porting
-SS	Stainless Steel Flanges & Trim

### Regulated Pressure Range (Manual)

Blank	High sensitivity	300 - 1600 psi (21 - 110 bar)
-1	Full range	300 - 3000 psi (21 - 207 bar)

### Regulated Pressure Range (Failsafe) (F or G models)

Blank	High sensitivity	300 - 1600 psi (21 - 110 bar)
-1	Full range	300 - 3000 psi (21 - 207 bar)