



OIL CLEANING CENTRIFUGE

Models 75, 75-1



FEATURES

- True Centrifuge
- Reduces Hazardous Waste
- Reduces Engine Wear
- Extends Oil and Filter Life
- Removes Solids Below One Micron
- Diagnostic Tool
- User Friendly
- Easy Installation
- Rugged Construction



Made in U.S.A.

INSTALLATION • SERVICE • PARTS

Parts List

Models 75 and 75-1

Centrifuge Model 75 (without cut-out valve assembly) ----- 75

Centrifuge Model 75-1 (with cut-out valve assembly) ----- 75-1

Parts List

Description	Part No.
Cover Assembly (no clamp) -----	C75-CA
Cover Nut -----	C75-13
Seal-Cover Nut -----	C75-12
Cover -----	C75-14
Snap Ring, Cover Nut -----	C75-18
Centrifuge Turbine Assembly -----	C75-TA
Nut-Turbine -----	C75-11
Cover-Turbine -----	C75-03
Seal-Turbine (2 req'd) -----	C75-10
Insert-Turbine (Package of 25) -----	C75-24P
Bowl-Turbine -----	C75-02
Baffle-Turbine -----	C75-04
Base, Turbine Assembly (sold as assembly only) -----	C75-BTA
Nozzle-Turbine (2 req'd) -----	C75-19
Model 75 Base Assembly (no clamp or cut-out valve) -----	C75-BA
Model 75-1 Base Assembly (no clamp) -----	C75-1-BA
Seal, Base to Cover -----	C75-15
Model 75 Base/Shaft (sold as assembly only) -----	C75-16-A
Model 75-1 Base/Shaft (sold as assembly only) -----	C75-16-1-A
Cut-out Valve Piston -----	C75-23
Cut-out Valve Spring -----	C75-22
Cut-out Valve Seal -----	C75-21
Cut-out Valve Plug -----	C75-20
Fitting, Inlet 9/16-18 UNF x 1/4 FNPT -----	C75-25

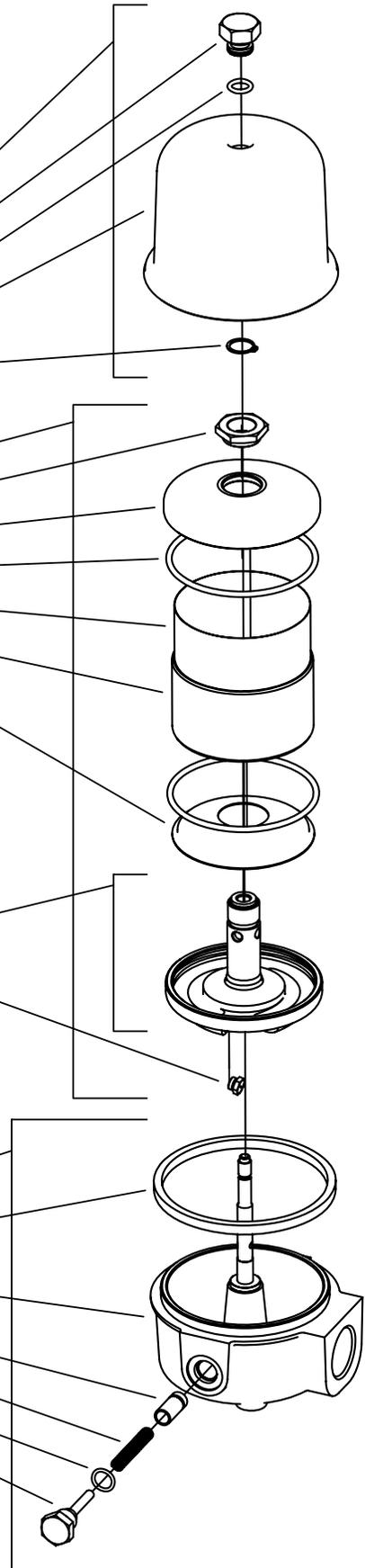

Installation and Operation

Oil Supply to Centrifuge

Oil supply should be taken from a source as close to the lube oil pump discharge as possible and on the dirty side of the full flow oil filter. A 1/4" NPT pipe or #6 hose supply should be used for supply with a full-opening ball valve installed in supply line to allow the centrifuge to be isolated for cleaning without shutting the engine down. The centrifuge will operate efficiently at 30 to 90 psig with the preferred pressure of 60 to 80 psig.

Clean Oil Return to Sump

The clean oil drain line to the sump should be a 1.0" minimum diameter unrestricted hose or pipe to a 1.0" connection located above the oil level is required. Alternate oil fill openings or drilled-and-tapped holes in crankcase doors are options that can be used. **The oil drain line should be free of any shut-off valves.**

The drain is correct if you can drop in a 1.0" diameter ball and it can freely roll through the drain line into the engine.

Mounting Considerations

SPINCLEAN™ Centrifuges are high-speed devices and should be securely mounted to prevent excessive vibration.

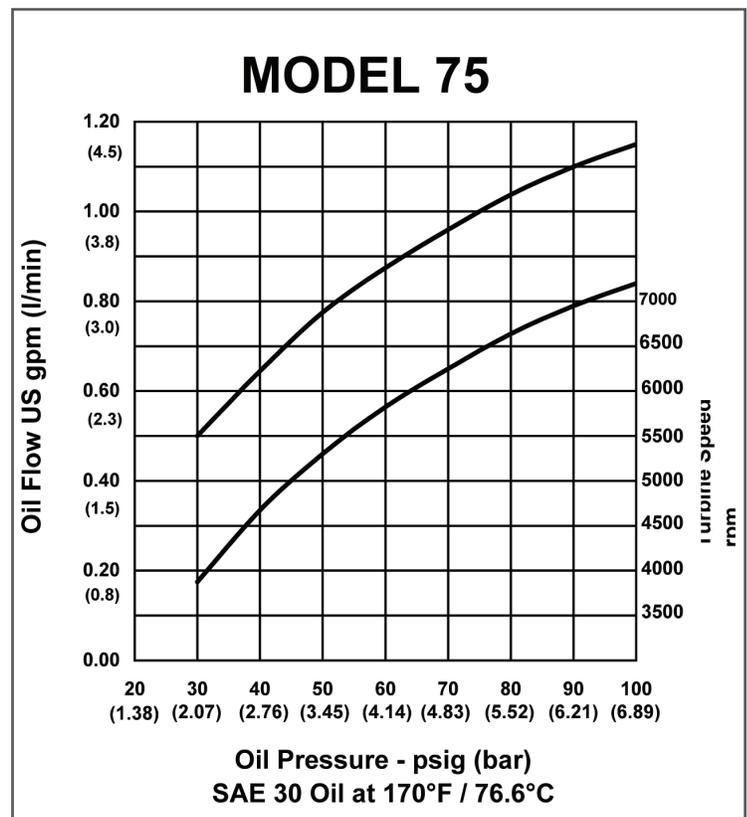
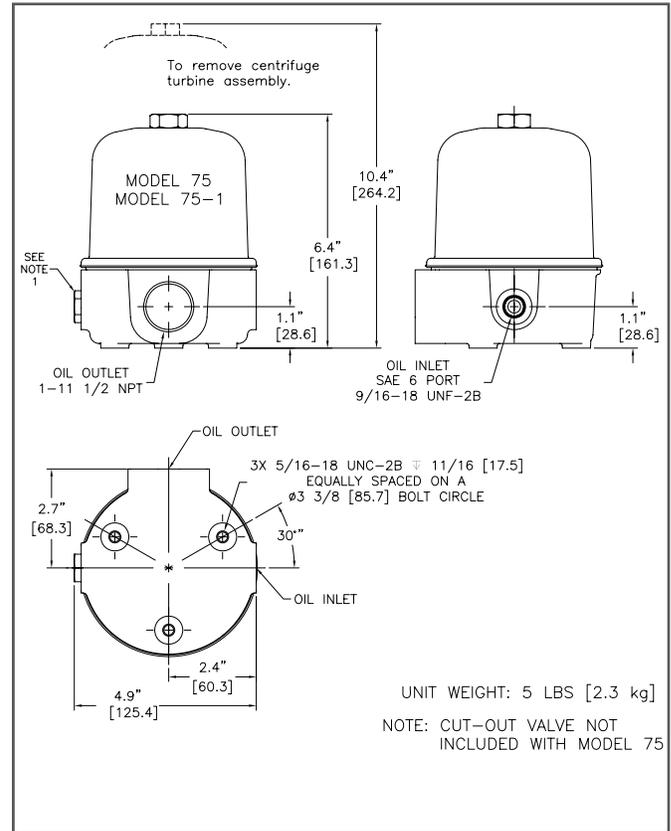

Service Instructions

1. Shut off oil supply or stop the engine and allow centrifuge turbine assembly to come to a complete stop. **The oil drain line should be free of any shut-off valves.**

2. Unscrew cover and remove cover assembly.

3. Lift the turbine assembly one inch and allow the oil to completely drain out of the nozzles before removing completely.

4. Remove turbine nut, **Part # C75-11**. Carefully separate the turbine assembly. **DO NOT strike the bushings with or against a hard surface or damage will result.**

5. Remove lower turbine bowl seal, **Part # C75-10**, and baffle, **Part # C75-04**.

6. Carefully remove the solids cake from the turbine bowl, **Part # C75-02**, taking care not to damage the turbine bowl. Thoroughly wash away all traces of the solids cake to insure maintaining turbine assembly balance.

7. Thoroughly clean all other turbine parts. Check turbine nozzles, **Part # C75-19**, and make sure they are unrestricted. Replace turbine bowl seals, **Part # C75-10**. Examine top and bottom bearings for excessive wear. Replace turbine base assembly, **Part # C75-BTA**, if diameters exceed 0.317" (8.1 mm) top or 0.396" (10.1 mm) bottom.

8. Seat baffle in turbine base and install lower turbine bowl seal, **Part # C75-10**. Install turbine insert, **Part # C75-24**, inside turbine bowl. Reassemble the turbine assembly tightening the turbine nut, **Part # C75-11** securely to a torque value of 10-15 in-lbs.

9. Examine stationary shaft journals for damage or excessive wear. Replace base assembly, **Part # C75-BA**, complete with stationary shaft if diameter is less than 0.312" (7.9 mm) top or 0.391" (9.9 mm) bottom. The stationary shaft is permanently installed and cannot be replaced.

10. Coat the stationary shaft with clean oil. Install the turbine assembly on the stationary shaft, being careful not to damage bearings. Spin turbine assembly on the stationary shaft and make sure it spins freely and unrestricted.

Model 75-1 only: Remove, clean and inspect the idle-cut-out-valve assembly and mating bore in housing. The piston should move freely.

11. Clean and inspect cover assembly, **Part # C75-CA**, and make sure the cover nut seal, **Part # C75-12**, is not leaking. If necessary, replace the seal by removing the cover nut snap ring, **Part # C75-18**, and remove the cover nut with seal from the cover.

12. Replace the base to cover seal, **Part # C75-15**.

13. Replace the cover assembly and tighten the cover nut by hand pressure plus another half turn. Make sure the cover seats evenly around the base to insure proper crush on cover to base seal to prevent oil leaks.

14. Turn on oil supply to the centrifuge. With centrifuge in operation, check complete installation for oil leaks or excessive vibration. If excessive vibration exists then disassemble, inspect and reassemble.

Note: All centrifuge turbines are factory tested for balance before leaving the factory. An out-of-balance condition can occur as a result of uneven build-up of dirt cake in the bowl or as a result of excessive bearing or stationary shaft wear. Depending on conditions, wear will eventually take place on the stationary shaft and bearings, requiring replacement of the appropriate assemblies.

SpinClean™ Representative:



75-11507

FLUID POWER ENERGY, INC.

W229 N591 Foster Court • Waukesha, WI 53186

Phone: 262.548.6220 • FAX: 262.548.6239

Website: www.fpevalves.com





OIL CLEANING CENTRIFUGE

Model 150



FEATURES

- True Centrifuge
- Reduces Hazardous Waste
- Reduces Engine Wear
- Extends Oil and Filter Life
- Removes Solids Below One Micron
- Diagnostic Tool
- User Friendly
- Easy Installation
- Rugged Construction



Made in U.S.A.

INSTALLATION • SERVICE • PARTS

Parts List

Model 150

Centrifuge ----- Model 150

Parts List

Description	Part No.
Cover Assembly (no clamp) -----	C150-CA
Cover Nut -----	C75-13
Seal-Cover Nut -----	C75-12
Cover -----	C150-14
Snap Ring, Cover Nut -----	C75-18
Centrifuge Turbine Assembly -----	C150-TA
Nut-Turbine -----	C75-11
Cover-Turbine -----	C150-03
Seal-Turbine (2 req'd) -----	C150-10
Insert-Turbine (Package of 25) -----	C150-24P
Bowl-Turbine -----	C150-02
Baffle-Turbine -----	C150-04
Base, Turbine Assembly (sold as assembly only) -----	C150-BTA
Nozzle-Turbine (2 req'd) -----	C150-19
Base Assembly (no clamp) -----	C150-BA
Seal, Base to Cover -----	C150-15
Base/Shaft (sold as assembly only) -----	C150-16-A
Cut-out Valve Snap Ring -----	1690
Cut-out Valve Retainer -----	C150-22
Cut-out Valve Spring -----	C150-23
Cut-out Valve Plug -----	C150-21
Seal, Cut-out Valve -----	C1000-29
Cut-out Valve Body -----	C150-20
Fitting, Inlet, 3/4-16 UNF x 1/2" FNPT -----	C150-26

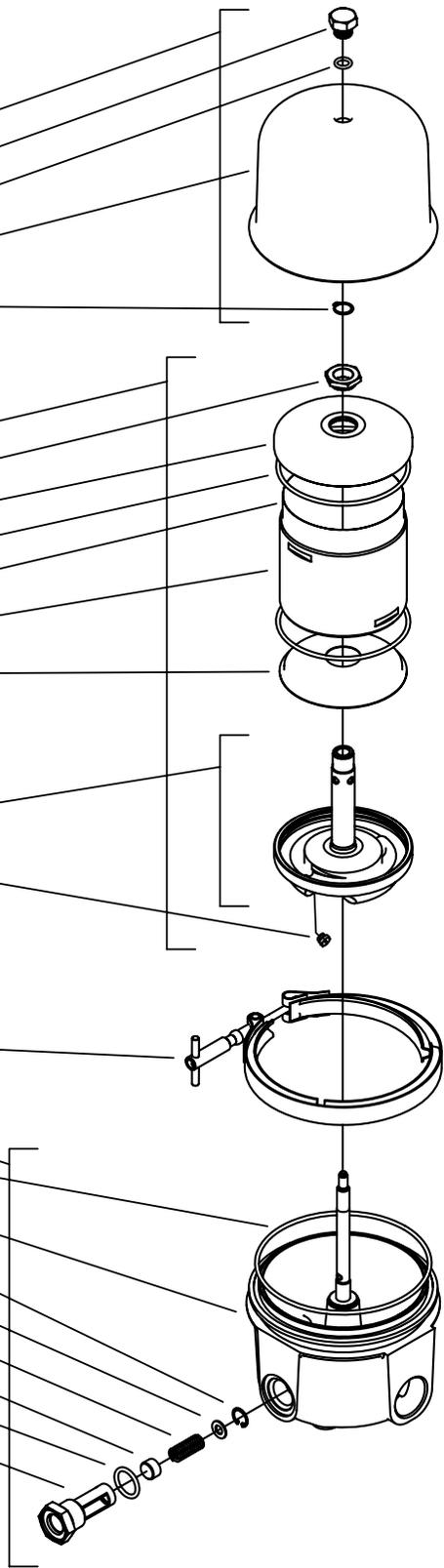

Installation and Operation

Oil Supply to Centrifuge

Oil supply should be taken from a source as close to the lube oil pump discharge as possible and on the dirty side of the full flow oil filter. A 1/4" NPT pipe or #6 hose supply should be used for supply with a full-opening ball valve installed in supply line to allow the centrifuge to be isolated for cleaning without shutting the engine down. The centrifuge will operate efficiently at 30 to 90 psig with the preferred pressure of 60 to 80 psig.

Clean Oil Return to Sump

The clean oil drain line to the sump should be a 1.0" minimum diameter unrestricted hose or pipe to a 1.0" connection located above the oil level is required. Alternate oil fill openings or drilled-and-tapped holes in crankcase doors are options that can be used. **The oil drain line should be free of any shut-off valves.**

The drain is correct if you can drop in a 1 1/4" diameter ball and it can freely roll through the drain line into the engine.

Mounting Considerations

SPINCLEAN™ Centrifuges are high-speed devices and should be securely mounted to prevent excessive vibration.

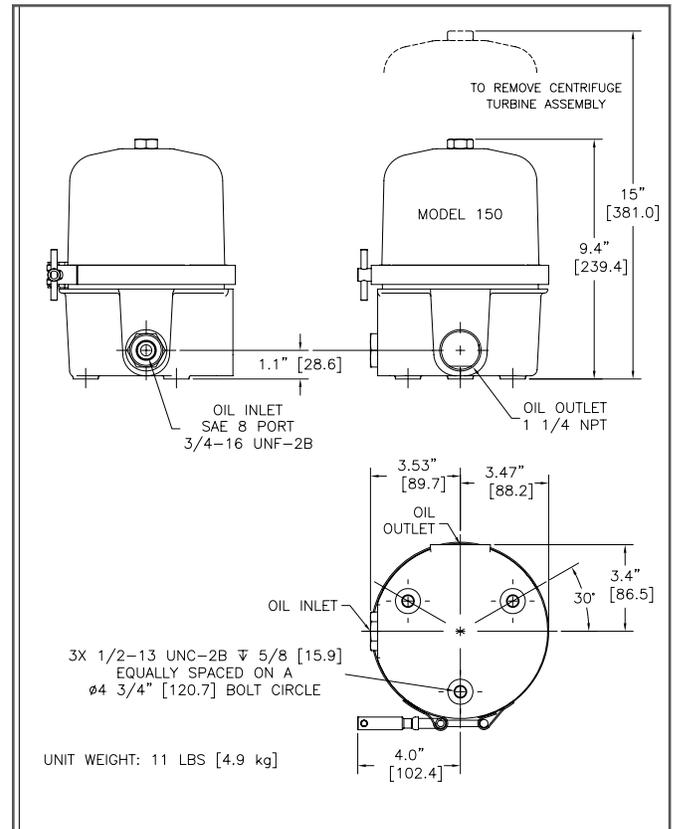

MODEL 150

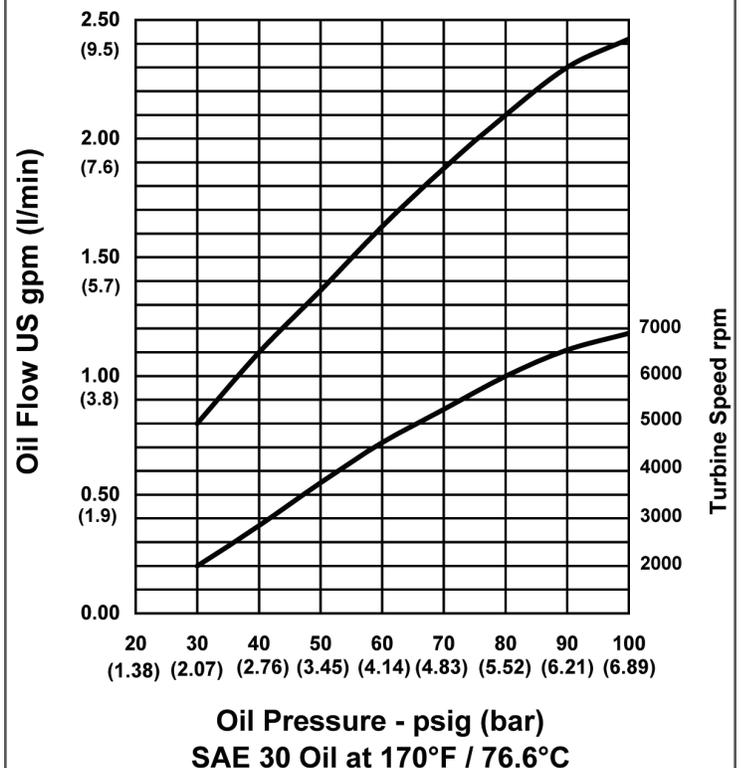

Service Instructions

1. Shut off oil supply or stop the engine and allow centrifuge turbine assembly to come to a complete stop. **The oil drain line should be free of any shut-off valves.**
2. Unscrew cover and remove cover assembly.
3. Lift the turbine assembly one inch and allow the oil to completely drain out of the nozzles before removing completely.
4. Remove turbine nut, **Part # C150-11**. Carefully separate the turbine assembly. **DO NOT strike the bushings with or against a hard surface or damage will result.**
5. Remove lower turbine bowl seal, **Part # C150-10**, and baffle, **Part # C150-04**.
6. Carefully remove the solids cake from the turbine bowl, **Part # C150-02**, taking care not to damage the turbine bowl. Thoroughly wash away all traces of the solids cake to insure maintaining turbine assembly balance.
7. Thoroughly clean all other turbine parts. Check turbine nozzles, **Part # C150-19**, and make sure they are unrestricted. Replace turbine bowl seals, **Part # C150-10**. Examine top and bottom bearings for excessive wear. Replace turbine base assembly, **Part # C150-BTA**, if diameters exceed 0.317" (8.1 mm) top or 0.396" (10.1 mm) bottom.
8. Seat baffle in turbine base and install lower turbine bowl seal, **Part # C150-10**. Install turbine insert, **Part # C150-24**, inside turbine bowl. Reassemble the turbine assembly tightening the turbine nut, **Part # C150-11** securely to a torque value of 10-15 in-lbs.
9. Examine stationary shaft journals for damage or excessive wear. Replace base assembly, **Part # C150-BA**, complete with stationary shaft if diameter is less than 0.312" (7.9 mm) top or 0.391" (9.9 mm) bottom. The stationary shaft is permanently installed and cannot be replaced.
10. Coat the stationary shaft with clean oil. Install the turbine assembly on the stationary shaft, being careful not to damage bearings. Spin turbine assembly on the stationary shaft and make sure it spins freely and unrestricted.
11. Clean and inspect cover assembly, **Part # C150-CA**, and make sure the cover nut seal, **Part # C150-12**, is not leaking. If necessary, replace the seal by removing the cover nut snap ring, **Part # C150-18**, and remove the cover nut with seal from the cover.
12. Replace the base to cover seal, **Part # C150-15**.
13. Replace the cover assembly and tighten the cover nut by hand pressure plus another half turn. Make sure the cover seats evenly around the base to insure proper crush on cover to base seal to prevent oil leaks.
14. Remove cut-out valve body, **Part # C150-20**, from cast base, **Part # C150-16**. Replace cut-out valve seal, **Part # C1000-29**. Inspect assembly to make sure cut-out valve plug, **Part # C150-21**, is seated against the cut-out valve body. Replace cut-out valve assembly into base securely to a torque value of 10-15 in-lbs.

SpinClean™ Representative:



150-12207

FLUID POWER ENERGY, INC.

W229 N591 Foster Court • Waukesha, WI 53186

Phone: 262.548.6220 • FAX: 262.548.6239

Website: www.fpevalves.com





OIL CLEANING CENTRIFUGE

Model 300



FEATURES

- True Centrifuge
- Reduces Hazardous Waste
- Reduces Engine Wear
- Extends Oil and Filter Life
- Removes Solids Below One Micron
- Diagnostic Tool
- User Friendly
- Easy Installation
- Rugged Construction



Made in U.S.A.

INSTALLATION • SERVICE • PARTS

Parts List

Model 300

Centrifuge, w/ Oil Control Base ----- Model 300-OCB

Centrifuge, only (gravity drain) ----- Model 300

Parts List

Description	Part No.
-------------	----------

Cover Assembly (no clamp) -----	C300-CA
--	----------------

Pin-Cover Nut -----	C300-12
---------------------	---------

Knob-Cover Nut -----	C300-14
----------------------	---------

Cover -----	C300-15
-------------	---------

Seal-Cover Nut -----	C300-09
----------------------	---------

Nut-Cover -----	C300-13
-----------------	---------

Clamp w/ Tee Handle-Cover to Base -----	C300-18
--	----------------

Centrifuge Turbine Assembly -----	C300-TA
--	----------------

Nut-Turbine -----	C300-11
-------------------	---------

Cover-Turbine -----	C300-03
---------------------	---------

Seal-Turbine (2 req'd) -----	C300-10
------------------------------	---------

Insert-Turbine (Package of 25) -----	C300-33P
--------------------------------------	----------

Bowl-Turbine -----	C300-02
--------------------	---------

Baffle-Turbine -----	C300-04
----------------------	---------

Base, Turbine Assembly (sold as assembly only) -----	C300-BTA
---	-----------------

Nozzle-Turbine (2 req'd) -----	C300-19-20
--------------------------------	------------

Base Assembly (no clamp) -----	C300-BA
---------------------------------------	----------------

Seal, Base to Cover -----	C300-17
---------------------------	---------

Base/Shaft (sold as assembly only) -----	C300-16-A
--	-----------

Piston, Cut Out Valve -----	C300-27
-----------------------------	---------

Spring, Cut Out Valve -----	C300-28
-----------------------------	---------

Seal, Cut Out Valve -----	C300-29
---------------------------	---------

Plug, Cut Out Valve -----	C300-30
---------------------------	---------

Fitting, Inlet 1/2" FNPT x 7/8 UNF -----	C300-23
--	---------

Base-Oil Control w/ Hardware -----	COCB-01
---	----------------

Base-Oil Control w/ Turbo Hardware -----	COCB-01T
---	-----------------

Seal, Oil Control Base -----	COCB-02
------------------------------	---------

Model 300 Service Tool Kit -----	C300-SK
---	----------------

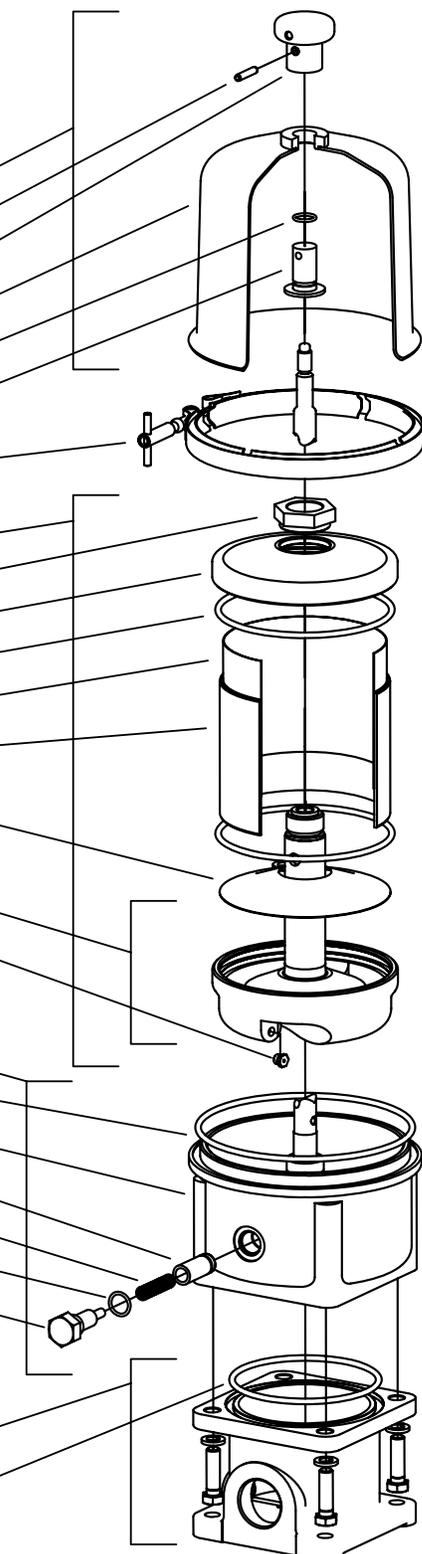

Installation and Operation

Oil Supply to Centrifuge

Oil supply should be taken from a source as close to the lube oil pump discharge as possible and on the dirty side of the full flow oil filter. A 1/2" NPT pipe or #8 hose supply should be used for supply with a full-opening ball valve installed in supply line to allow the centrifuge to be isolated for cleaning without shutting the engine down. The centrifuge will operate efficiently at 30 to 90 psig with the preferred pressure of 60 to 80 psig. Below 30 psig, an internal idle cutout valve will close to prevent low oil pressure during low engine RPM.

Clean Oil Return to Sump Using Oil Control Base (OCB) Preferred

The oil control base, **Part # COCB-01** permits the Model 300 centrifuge to be installed in any convenient location near the engine.

The clean oil drain line to the sump should be a 1" minimum diameter, unrestricted hose or pipe. A 1" connection located above the oil level is preferred. Alternate oil fill openings or drilled-and-tapped holes in crankcase doors are options that can be used. A below oil-level-return will require the use of a 1 1/2" check valve, Part # C300-24, located at the OCB oil outlet connection to prevent back-flow when the centrifuge is being serviced. Only low pressure drop check valves are permitted in the drain line, manual shut-off valves should never be used on the drain line.

The OCB controls the oil flow from the centrifuge back to the engine and insures the centrifuge reaches maximum speed and efficiency. To accomplish this, the OCB uses a very small volume of compressed air; approximately 0.02 SCFM. The OCB is capable of receiving compressed air from any 5 to 400 psig source. If there is no compressed air available it may be possible to use turbocharger air or air from a positive displacement blower. Instructions for this type installation are available from your SPIN-CLEAN™ representative.

Using Gravity Drain Engine Mounting Only

For gravity drain without the OCB, the SPIN-CLEAN™ centrifuge must be close-coupled to the engine sump using an unrestricted 2" I.D. drain back into the engine above the engine normal oil level. A crankcase door, inspection cover, etc. can be modified to provide a suitable oil return back into the engine. The drain is correct if you can drop in a 4" diameter ball and it can freely roll through the drain line into the engine.

Mounting Considerations

SPINCLEAN™ Centrifuges are high-speed devices and should be securely mounted to prevent excessive vibration. Model 300 may be installed up to 15 degrees from vertical.

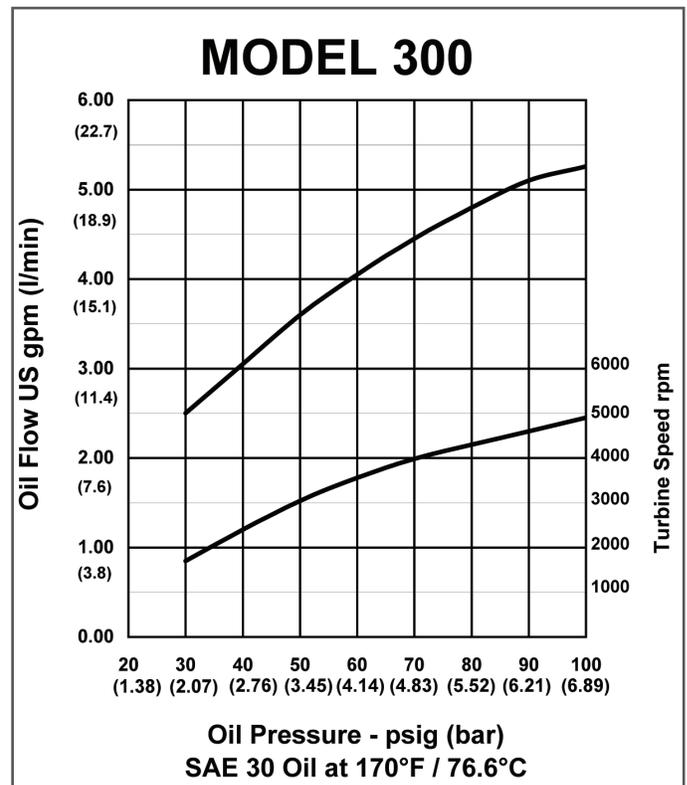
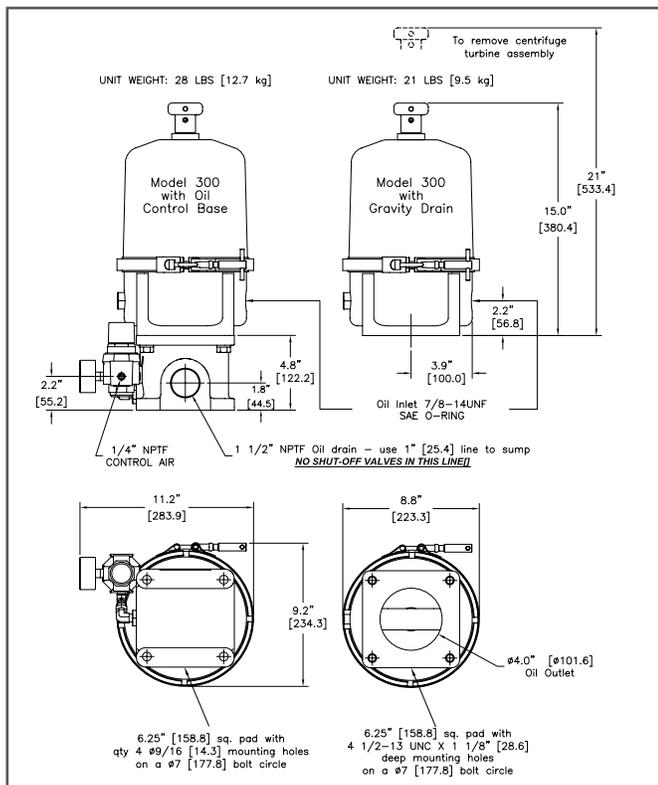

Service Instructions

1. Shut off oil supply or stop the engine and allow centrifuge turbine assembly to come to a complete stop. **Caution:** Open safety bleed valve on side of the Oil Control Base (if equipped) and be certain that the unit is not pressurized. If safety bleed valve is under pressure, locate the source and remove before proceeding. **The oil drain line should be free of any shut-off valves.**

2. Remove cover clamp, unscrew cover and remove cover assembly.

3. Lift the turbine assembly a couple of inches and allow the oil to completely drain out of the nozzles before removing completely. Carefully separate the turbine assembly. **Do not strike the bushings with or against a hard surface or damage will result.** Remove lower turbine bowl seal and then remove baffle.

4. Carefully remove the solid cake from the turbine bowl, **Part # C300-02**, taking care not to damage the turbine bowl. Thoroughly wash away all traces of the solid cake to insure maintaining turbine balance.

5. Thoroughly clean all other turbine parts. Check turbine nozzles and make sure they are unrestricted. Inspect turbine bowl seals, **Part # C300-10**, for cuts or damage; they can be used several times. Examine top and bottom bearings for excessive wear. Replace turbine base assembly, **Part # C300-BTA**, if diameters exceed 0.503" (12.8 mm) top or 0.879" (22.3 mm) bottom.

6. Seat baffle in turbine base and install lower turbine bowl seal, **Part # C300-10**, in the turbine base. Install turbine insert, **Part # C300-33**, inside the turbine bowl. Reassemble the turbine assembly tightening the bowl nut securely **using finger pressure only.**

7. Examine stationary shaft journals for damage or excessive wear. Replace base assembly, **Part # C300-BA**, if diameter is less than 0.496" (12.6 mm) top or 0.871" (22.1 mm) bottom. The stationary shaft is permanently installed and cannot be replaced.

8. Remove, clean and inspect the idle-cut-out-valve assembly and mating bore in housing. The piston should move freely in the bore. If damaged replace with **Part # C300-27.**

9. If OCB is used check for proper mechanical operation and structural integrity.

10. Coat the stationary shaft with clean oil. Install the turbine assembly on the stationary shaft, being careful not to damage bearings. Spin turbine assembly on the stationary shaft and make sure it spins freely and unrestricted.

11. Clean and inspect cover and make sure the cover seal, **Part # C300-09**, is not leaking. If necessary, replace the seal by removing the roll pin below the hand knob and remove the nut from the bottom.

12. Inspect the base to cover seal, **Part # C300-17**, and replace if necessary.

13. Replace the cover assembly and tighten the cover knob by hand pressure plus another half turn. Make sure the cover seats on the base evenly all around to insure proper crush on cover seal to prevent oil leaks. Reinstall the cover clamp and tighten securely.

14. Close safety bleed valve on the Oil Control Base. Turn on air supply and oil supply to the centrifuge. With engine running, check complete installation for oil leaks or excessive vibration. If excessive vibration exist then disassemble, inspect and reassemble.

Note: All centrifuge turbines are factory tested for balance before leaving the factory. An out-of-balance condition can occur as a result of uneven build up of dirt cake in the bowl or as a result of excessive bearing or stationary shaft wear. Depending on conditions, wear will eventually take place on the stationary shaft and bearings, requiring replacement of the appropriate assemblies.

SpinClean™ Representative:



300-11507

FLUID POWER ENERGY, INC.

W229 N591 Foster Court • Waukesha, WI 53186

Phone: 262.548.6220 • FAX: 262.548.6239

Website: www.fpevalves.com





OIL CLEANING CENTRIFUGE

Model 1000



FEATURES

- True Centrifuge
- Reduces Hazardous Waste
- Reduces Engine Wear
- Extends Oil and Filter Life
- Removes Solids Below One Micron
- Diagnostic Tool
- User Friendly
- Easy Installation
- Rugged Construction



Made in U.S.A.

INSTALLATION • SERVICE • PARTS

Parts List

Model 1000

Centrifuge, w/ Oil Control Base ----- Model 1000-OCB

Centrifuge, only (gravity drain) ----- Model 1000

Parts List

Description	Part No.
Cover Assembly (no clamp) -----	C1000-CA
Pin-Cover Nut -----	C1000-12
Knob-Cover Nut -----	C1000-14
Seal-Cover Nut -----	C1000-09
Nut-Cover -----	C1000-13
Cover -----	C1000-26
Clamp w/ Tee Handle-Cover to Base -----	C1000-32
Centrifuge Turbine Assembly -----	C1000-TA
Nut-Turbine -----	C1000-11
Cover-Turbine -----	C1000-03
Seal-Turbine (2 req'd) -----	C1000-10
Insert-Turbine (Package of 25) -----	C1000-33P
Bowl-Turbine -----	C1000-02
Baffle-Turbine -----	C1000-04
Base, Turbine Assembly (sold as assembly only) -----	C1000-BTA
Nozzle-Turbine (2 req'd) -----	C300-19-80
Base Assembly (no clamp) -----	C1000-BA
Seal, Base to Cover -----	C1000-25
Base/Shaft (sold as assembly only) -----	C1000-24-A
Piston, Cut Out Valve -----	C1000-27
Spring, Cut Out Valve -----	C1000-28
Seal, Cut Out Valve -----	C1000-29
Plug, Cut Out Valve -----	C1000-30
Fitting, Inlet 1" FNPT X 1 5/16 SAE -----	C1000-23
Base-Oil Control w/ Hardware -----	COCB-01
Base-Oil Control w/ Turbo Hardware -----	COCB-01T
Seal, Oil Control Base -----	COCB-02
Model 1000 Service Tool Kit -----	C1000-SK

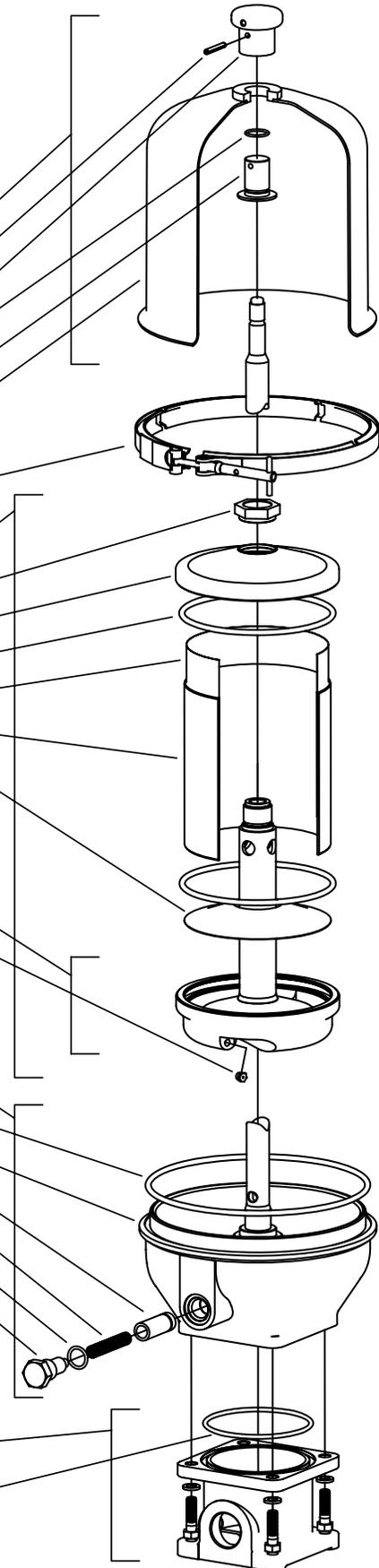

Installation and Operation

Oil Supply to Centrifuge

Oil supply should be taken from a source as close to the lube oil pump discharge as possible and on the dirty side of the full flow oil filter. A 3/4" NPT pipe or #12 hose supply should be used for supply with a full-opening ball valve installed in supply line to allow the centrifuge to be isolated for cleaning without shutting the engine down. The centrifuge will operate efficiently at 30 to 90 psig with the preferred pressure of 60 to 80 psig. Below 30 psig, an internal idle cutout valve will close to prevent low oil pressure during low engine RPM.

Clean Oil Return to Sump

The oil drain line should be free of any shut-off valves.

Using Oil Control Base (OCB) Preferred

The oil control base, **Part # COCB-01** permits the Model 1000 centrifuge to be installed in any convenient location near the engine.

The clean oil drain line to the sump should be a 1- 1/2" minimum diameter, unrestricted hose or pipe. A 1-1/2" connection located above the oil level is preferred. Alternate oil fill openings or drilled-and-tapped holes in crankcase doors are options that can be used. A below oil-level-return will require the use of a 1 1/2" check valve, Part # C300-24, located at the OCB oil outlet connection to prevent back-flow when the centrifuge is being serviced.

Only low pressure drop check valves are permitted in the drain line, manual shut-off valves should never be used on the drain line.

The OCB controls the oil flow from the centrifuge back to the engine and insures the centrifuge reaches maximum speed and efficiency. To accomplish this, the OCB uses a very small volume of compressed air; approximately 0.02 SCFM. The OCB is capable of receiving compressed air from any 5 to 400 psig source. If there is no compressed air available it may be possible to use turbocharger air or air from a positive displacement blower. Instructions for this type installation are available from your SPIN-CLEAN™ representative.

Using Gravity Drain Engine Mounting Only

For gravity drain without the OCB, the SPIN-CLEAN™ centrifuge must be close-coupled to the engine sump using an unrestricted 4" I.D. drain back into the engine above the engine normal oil level. A crankcase door, inspection cover, etc. can be modified to provide a suitable oil return back into the engine. The drain is correct if you can drop in a 4" diameter ball and it can freely roll through the drain line into the engine.

Mounting Considerations

SPINCLEAN™ Centrifuges are high-speed devices and should be securely mounted to prevent excessive vibration. Model 1000 may be installed up to 15 degrees from vertical.

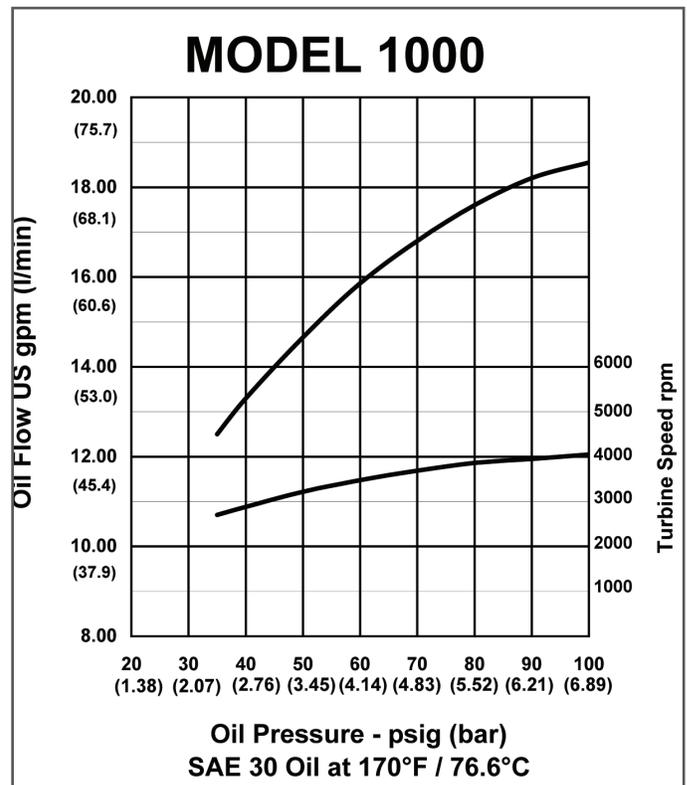
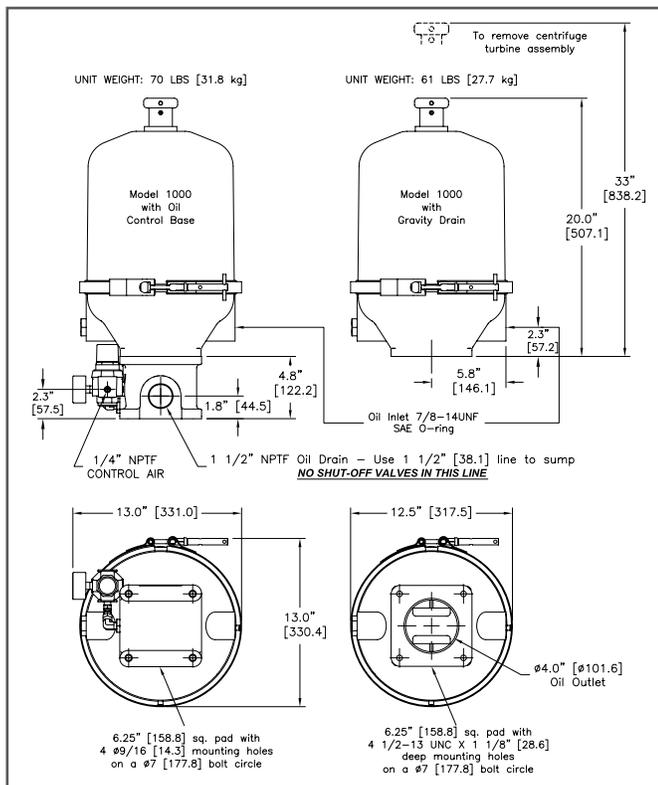

Service Instructions

1. Shut off oil supply or stop the engine and allow centrifuge turbine assembly to come to a complete stop. **Caution:** Open safety bleed valve on side of the Oil Control Base (if equipped) and be certain that the unit is not pressurized. If safety bleed valve is under pressure, locate the source and remove before proceeding. **The oil drain line should be free of any shut-off valves.**

2. Remove cover clamp, unscrew cover and remove cover assembly.

3. Lift the turbine assembly a couple of inches and allow the oil to completely drain out of the nozzles before removing completely. Carefully separate the turbine assembly. **Do not strike the bushings with or against a hard surface or damage will result.** Remove lower turbine bowl seal and then remove baffle.

4. Carefully remove the solid cake from the turbine bowl, **Part # C1000-02**, taking care not to damage the turbine bowl. Thoroughly wash away all traces of the solid cake to insure maintaining turbine balance.

5. Thoroughly clean all other turbine parts. Check turbine nozzles and make sure they are unrestricted. Inspect turbine bowl seals, **Part # C1000-10**, for cuts or damage; they can be used several times. Examine top and bottom bearings for excessive wear. Replace turbine base assembly, **Part # C1000-BTA**, if diameters exceed 0.877" (22.3 mm) top or 1.378" (35.0 mm) bottom.

6. Seat baffle in turbine base and install lower turbine bowl seal, **Part # C1000-10**, in the turbine base. Install turbine insert, **Part # C1000-33**, inside the turbine bowl. Reassemble the turbine assembly tightening the bowl nut securely **using finger pressure only.**

7. Examine stationary shaft journals for damage or excessive wear. Replace base assembly, **Part # C1000-BA**, if diameter is less than 0.870" (22.1 mm) top or 1.370" (34.8 mm) bottom. The stationary shaft is permanently installed and cannot be replaced.

8. Remove, clean and inspect the idle-cut-out-valve assembly and mating bore in housing. The piston should move freely in the bore. If damaged replace with **Part # C1000-27.**

9. If OCB is used check for proper mechanical operation and structural integrity.

10. Coat the stationary shaft with clean oil. Install the turbine assembly on the stationary shaft, being careful not to damage bearings. Spin turbine assembly on the stationary shaft and make sure it spins freely and unrestricted.

11. Clean and inspect cover and make sure the cover seal, **Part # C1000-09**, is not leaking. If necessary, replace the seal by removing the roll pin below the hand knob and remove the nut from the bottom.

12. Inspect the base to cover seal, **Part # C1000-25**, and replace if necessary.

13. Replace the cover assembly and tighten the cover knob by hand pressure plus another half turn. Make sure the cover seats on the base evenly all around to insure proper crush on cover seal to prevent oil leaks. Reinstall the cover clamp and tighten securely.

SpinClean™ Representative:



1000-11507

FLUID POWER ENERGY, INC.

W229 N591 Foster Court • Waukesha, WI 53186

Phone: 262.548.6220 • FAX: 262.548.6239

Website: www.fpevalves.com





OIL CLEANING CENTRIFUGE

Model M300



FEATURES

- True Centrifuge
- Reduces Hazardous Waste
- Reduces Engine Wear
- Extends Oil and Filter Life
- Removes Solids Below One Micron
- Diagnostic Tool
- User Friendly
- Easy Installation
- Rugged Construction



Made in U.S.A.

Installation • Service • Parts

Parts List

Model M300

Parts List

Description	Part No.
Cover Assembly (no clamp) -----	C300-CA
Pin-Cover Nut -----	C300-12
Knob-Cover Nut -----	C300-14
Cover -----	C300-15
Seal-Cover Nut -----	C300-09
Nut-Cover -----	C300-13
Clamp w/ Tee Handle-Cover to Base -----	C300-18
Centrifuge Turbine Assembly -----	C300-TA
Nut-Turbine -----	C300-11
Cover-Turbine -----	C300-03
Seal-Turbine (2 req'd) -----	C300-10
Insert-Turbine (Package of 25) -----	C300-33P
Bowl-Turbine -----	C300-02
Baffle-Turbine -----	C300-04
Base, Turbine Assembly (sold as assembly only) -----	C300-BTA
Nozzle-Turbine (2 req'd) -----	C300-19-20
Base Assembly (no clamp) -----	C300-MBA
Seal, Base to Cover -----	C300-17
Base/Shaft (sold as assembly only) -----	C300M-16-A
Model 300 Service Tool Kit -----	C300-SK

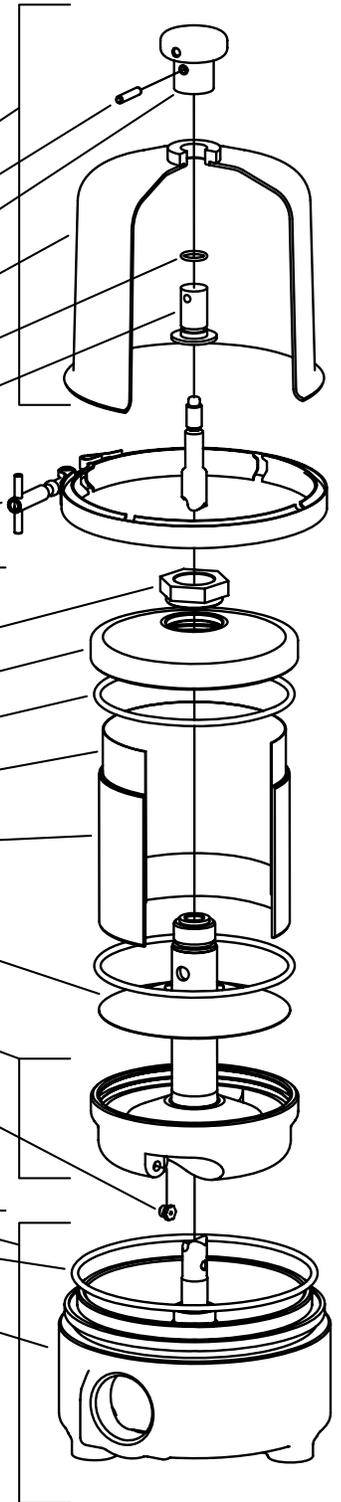

Installation and Operation

Oil Supply to Centrifuge

Oil supply should be taken from a source as close to the lube oil pump discharge as possible and on the dirty side of the full flow oil filter. A 1/2" NPT pipe or #8 hose supply should be used for supply with a full-opening ball valve installed in supply line to allow the centrifuge to be isolated for cleaning without shutting the engine down. The centrifuge will operate efficiently at 30 to 90 psig with the preferred pressure of 60 to 80 psig.

Clean Oil Return to Sump

The clean oil drain line to the sump should be a 2.0" minimum diameter unrestricted hose or pipe to a 2.0" connection located above the oil level is required. Alternate oil fill openings or drilled-and-tapped holes in crankcase doors are options that can be used.

The drain is correct if you can drop in a 2.0" diameter ball and it can freely roll through the drain line into the engine. **The oil drain line should be free of any shut-off valves.**

Mounting Considerations

SPINCLEAN™ Centrifuges are high-speed devices and should be securely mounted to prevent excessive vibration.

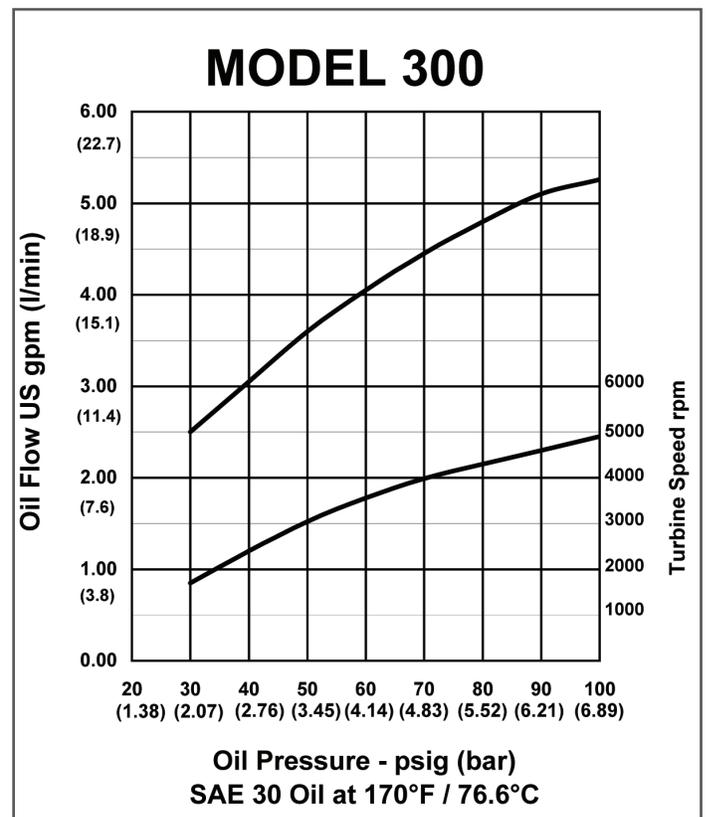
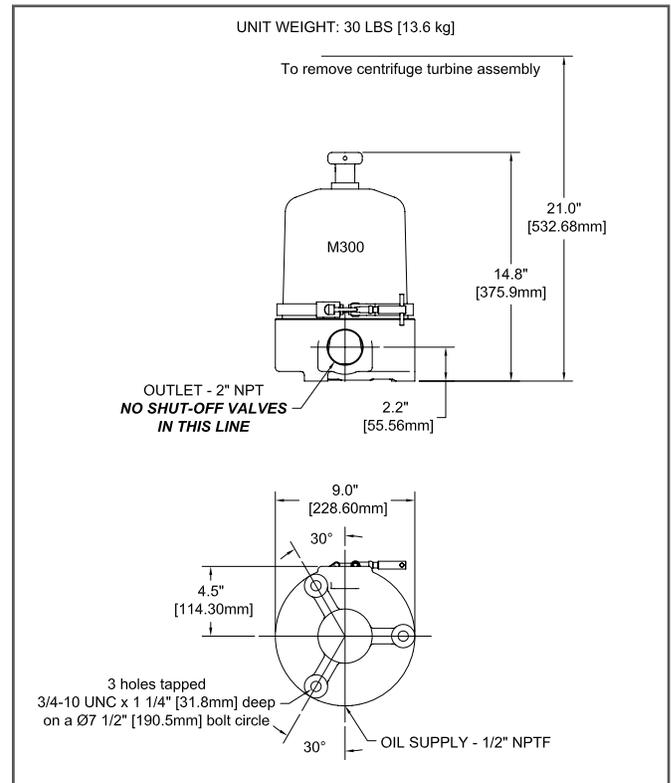

Service Instructions

1. Shut off oil supply or stop the engine and allow centrifuge turbine assembly to come to a complete stop.
2. Remove cover clamp, unscrew cover and remove cover assembly.
3. Lift the turbine assembly a couple of inches and allow the oil to completely drain out of the nozzles before removing completely. Carefully separate the turbine assembly. **Do not strike the bushings with or against a hard surface or damage will result.** Remove lower turbine bowl seal and then remove baffle.
4. Carefully remove the solids cake from the turbine bowl, **Part # C300-02**, taking care not to damage the turbine bowl. Thoroughly wash away all traces of the solids cake to insure maintaining turbine balance.
5. Thoroughly clean all other turbine parts. Check turbine nozzles and make sure they are unrestricted. Inspect turbine bowl seals, **Part # C300-10**, for cuts or damage; they can be used several times. Examine top and bottom bearings for excessive wear. Replace turbine base assembly, Part # **C300-BTA**, if diameters exceed 0.503" (12.8 mm) top or 0.879 (22.3 mm) bottom.
6. Seat baffle in turbine base and install lower turbine bowl seal, **Part # C300-10**, in the turbine base. Install turbine insert, **Part # C300-33**, inside the turbine bowl. Reassemble the turbine assembly tightening the turbine nut securely using finger pressure only.
7. Examine stationary shaft journals for damage or excessive wear. Replace base assembly, **Part # C300-MBA**, if diameter is less than 0.496" (12.6 mm) top or 0.871" (22.1 mm) bottom. The stationary shaft is permanently installed and cannot be replaced.
8. Coat the stationary shaft with clean oil. Install the turbine assembly on the stationary shaft, being careful not to

damage bushings. Spin turbine assembly on the stationary shaft and make sure it spins freely and unrestricted.

9. Clean and inspect cover and make sure the cover seal is not leaking. If necessary, replace the seal, **Part # C300-09**, by removing the roll pin below the hand knob and remove the nut from the bottom.
10. Inspect the base to cover seal, **Part # C300-17**, and replace if necessary.
11. Replace the cover assembly and tighten the cover nut by hand pressure plus another half turn. Make sure the cover seats evenly around the base to insure proper crush on cover to base seal to prevent oil leaks. Reinstall the cover clamp and tighten securely.
12. Turn on oil supply to the centrifuge. With engine running, check complete installation for oil leaks or excessive vibration. If excessive vibration exists then disassemble, inspect and reassemble.

Note: All centrifuge turbines are factory tested for balance before leaving the factory. An out-of-balance condition can occur as a result of uneven build up of dirt cake in the bowl or as a result of excessive bearing or stationary shaft wear. Depending on conditions, wear will eventually take place on the stationary shaft and bearings, requiring replacement of the appropriate assemblies.

SpinClean™ Representative:



M300-11507

FLUID POWER ENERGY, INC.

W229 N591 Foster Court • Waukesha, WI 53186
Phone: 262.548.6220 • FAX: 262.548.6239

Website: www.fpe.com

