

SPECIALTY GAGES:

Welding Pad

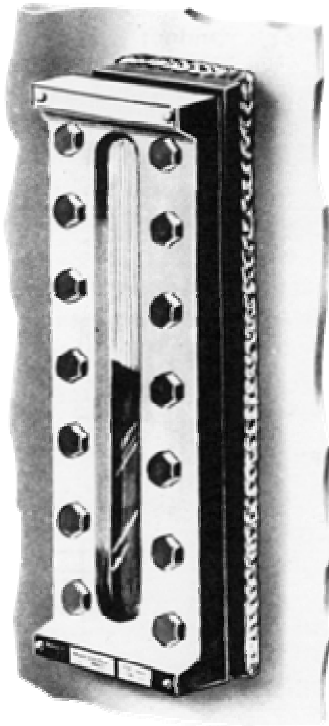

Glass-Trac Welding Pad Gages are used when standard tank connections cannot be used or when the liquid has solids in suspension. The gage becomes an integral part of the vessel because it is welded right onto the outer wall. Reflex or Transparent glass is used in any of nine standard lengths. Standard covers are 3 1/8" wide. **NOTES:** Welding pad gages to be used on vessels less than 36" in diameter must be special ordered. The welding pad body must be machined to allow proper fit up.

Method of Installation:

1. Assemble complete gage with spacer plate (available on request) in place of gage glass.
2. Place gage in exact location desired on empty vessel and weld around circumference of the pad.
3. Allow gage to cool, then remove cover and spacer. Drill or burn top and bottom holes in vessel wall at the top and bottom of each gage slot. Slot is 5/8" wide.
4. Replace gage glass, gasket, cushion and cover. Torque bolts to prescribed foot/pounds.

NOTES: While the gage itself can be designed to withstand certain pressures. Glass-Trac cannot control the installation of each gage or the load applied to the gage by the vessel. Because of this, Glass-Trac cannot rate Weld Pad Gages.

When ordering, add WP to gage size number.

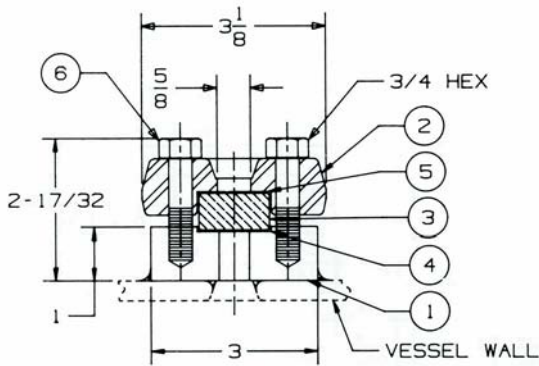

SECTION X-X
REFLEX

PARTS

ITEM NO.	NAME	MATERIAL
1	WELDING PAD	AISI 1020 HR
2	COVER	CARBON STEEL
3	GLASS	TEMPERED
4	GASKET	NON-ASBESTOS
5	CUSHION	NON-ASBESTOS
6	BOLT	ASTM A193 B7

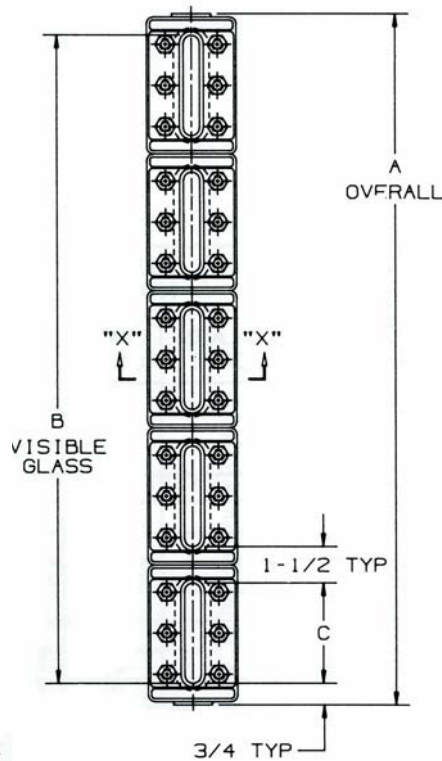

DIMENSIONS

GLASS SIZE	NO. SEC T.	DIMENSIONS (IN INCHES)		
		A	B	C
1	1	5 1/4	3 3/4	3 3/4
2	1	6 1/4	4 3/4	4 3/4
3	1	7 1/4	5 3/4	5 3/4
4	1	8 1/4	6 3/4	6 3/4
5	1	9 3/8	7 7/8	7 7/8
6	1	10 5/8	9 1/8	9 1/8
7	1	11 3/4	10 1/4	10 1/4
8	1	13 3/8	11 7/8	11 7/8
9	1	14 1/8	12 5/8	12 5/8
3	2	14 1/2	13	5 3/4
4	2	16 1/2	15	6 3/4
5	2	18 3/4	17 1/4	7 7/8
6	2	21 1/4	19 3/4	9 1/8
7	2	23 1/2	22	10 1/4
8	2	26 3/4	25 1/4	11 7/8
9	2	28 1/4	26 3/4	12 5/8
6	3	31 7/8	30 3/8	9 1/8
7	3	35 1/4	33 3/4	10 1/4
8	3	40 1/8	38 5/8	11 7/8
9	3	42 3/8	40 7/8	12 5/8
7	4	47	45 1/2	10 1/4
8	4	53 1/2	52	11 7/8
9	4	56 1/2	55	12 5/8
7	5	58 3/4	57 1/4	10 1/4
8	5	66 7/8	65 3/8	11 7/8
9	5	70 5/8	69 1/8	12 5/8