

Differential Pressure Battery Chargers

Converting Pipeline Energy to Battery Power



An Efficient and Reliable Alternative to Solar Panels

Parker's DB1 Differential Pressure Battery Charger is a versatile alternative to solar panel systems that are used to power electronic instruments on gas pipelines. Unlike solar panels, the DB1 can be installed in almost any location and is unaffected by shade, snow, freezing rain, ice, or dust build-up.

In applications such as wireless communications at remote monitoring sites, the DB1 produces a 12- or 24-volt power output to keep the battery fully charged. The battery's temperature and charge level are continuously monitored and the DB1 produces up to 50 watts to keep it charged.



Contact Information:

Sold and Serviced by:



5631 Burbank Rd SE, Calgary, AB, T2H 1Z5
Phone: 403-253-8320
info@zimco.ca / www.zimco.ca

Product Features:

- Free uninterruptible power 24/7
- 10, 20 and 50 watt units available
- RS-485 Serial / Ethernet MODBUS protocol communications option
- Severe service option - wetted parts suitable up to 8% H₂S and 8% CO₂
- 12 or 24 volts – field selectable
- Consumes no gas
- Emission free
- Class I, Division 1, Group D certified
- Operates in parallel with station regulators
- Only 30-65 SCFM bypass flow when charging
- Maintenance free
- Compact design eliminates theft and vandalism



ENGINEERING YOUR SUCCESS.

DB1 Overview

Introduction to the DB1

The DB1 Differential Pressure Battery Charger is an efficient and reliable alternative to solar panel systems that are used to power electronic instruments on gas pipelines. In applications where a lead acid battery is used to provide high peak power for short burst requirements (such as for wireless communications at remote monitoring sites), the DB1 produces a 12- or 24-volt power output to keep the battery fully charged. The battery's temperature and charge level are continuously monitored and the DB1 produces up to 50 watts to keep it charged.

Unlike solar panels, the DB1 can be installed in almost any location and is unaffected by shade, snow, freezing rain, ice, dust build-up, or birds.

The DB1 battery charger uses the differential pressure developed across a pressure regulator* on natural gas pipelines to run a small turbine-powered Generator. Controlled start-up for the DB1 makes turning the system ON as simple as flipping a switch. The Generator output is used to charge a lead acid battery – similar to Parker's Thermo-Electric Chargers (TECs). Unlike the TECs, the DB1 does not consume any natural gas. Power is produced by allowing a small portion of the gas to flow through a turbine, bypassing the pressure regulating valve. The amount of gas flowing through the DB1 turbine is low relative to the total line flow, and remains stable, keeping the DB1 transparent to the pressure control system. The pressure regulator automatically adjusts for the slight decrease in flow resulting when the DB1 runs.

The power produced by the DB1 is micro-processor controlled to provide the ideal temperature compensated battery charging current and voltage to the battery. The DB1 also provides internal diagnostics to detect possible system problems. The system status can be locally or remotely monitored using the open collector alarm output. An optional communications controller is available to provide real-time communications with the DB1.

* See 'System Regulator' on page 3 diagram

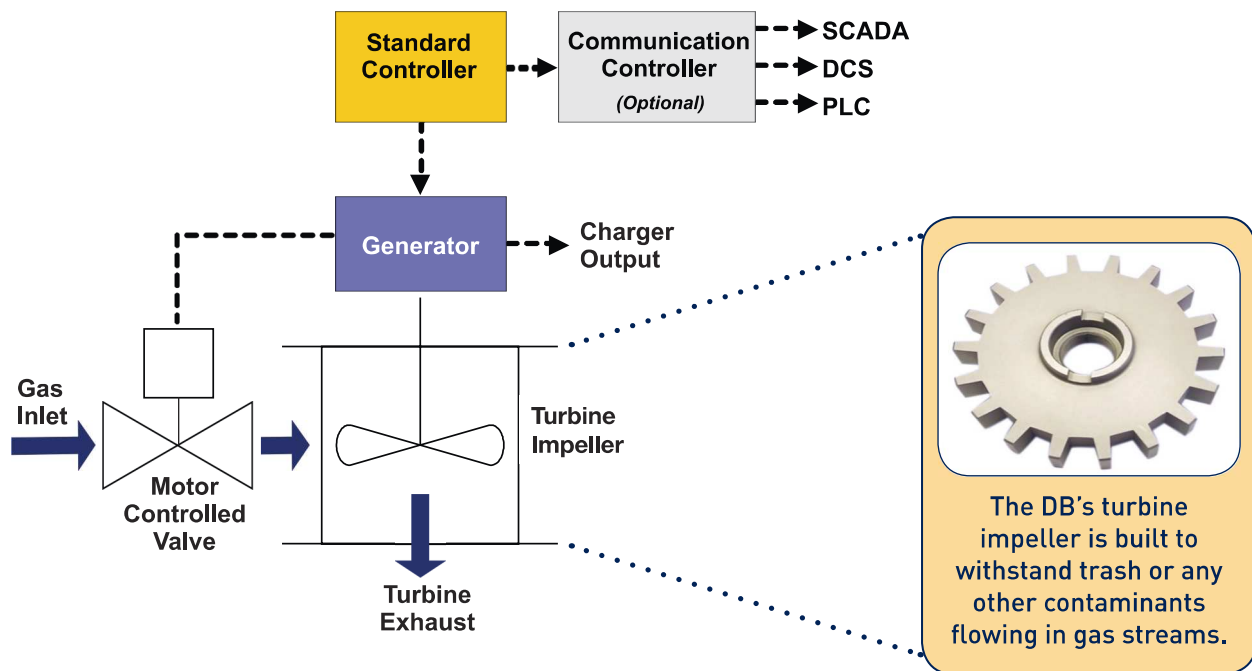

DB1 Installation Overview



- Powered by natural gas up to 1440 psig system pressures
- Severe service option - wetted parts suitable up to 8% H₂S and 8% CO₂
- Microprocessor controlled simple start up and diagnostics
- Optional real-time communications controller: RS-485 serial / ethernet MODBUS protocol
- Integrated temperature compensated charger with remote battery temperature sensor
- Status output for remote monitoring
- Controller firmware field ungradable

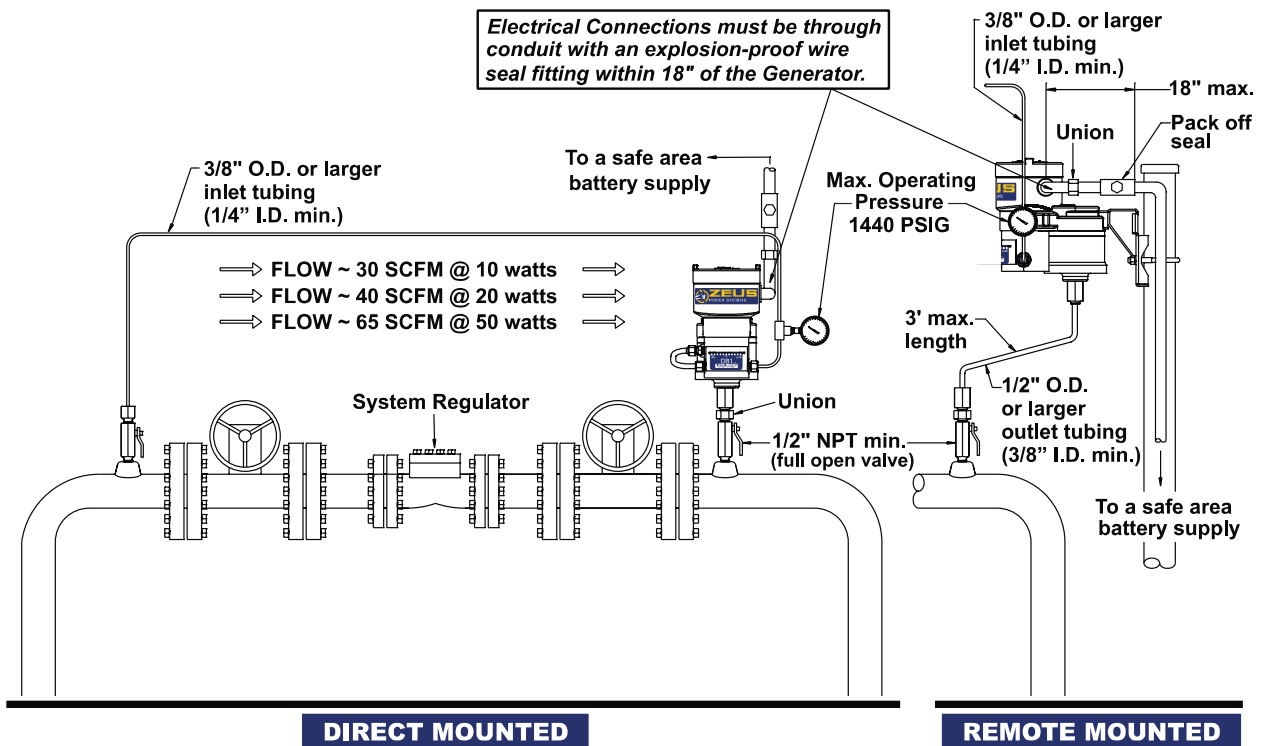

Minimum Required Pressure Differential

65 PSIG for 10 watts
 85 PSIG for 20 watts
 125 PSIG for 50 watts

DB1 System Overview

System Overview

The DB1 system consists of three main components: the Generator, the Controller (or Optional Communications Controller), and the Battery Interface Module. The Generator is installed on or near the pipeline, typically in a division 1 or 2 hazardous location.

The Controller and Battery Interface Module should be mounted on or near the battery, in a safe area location.

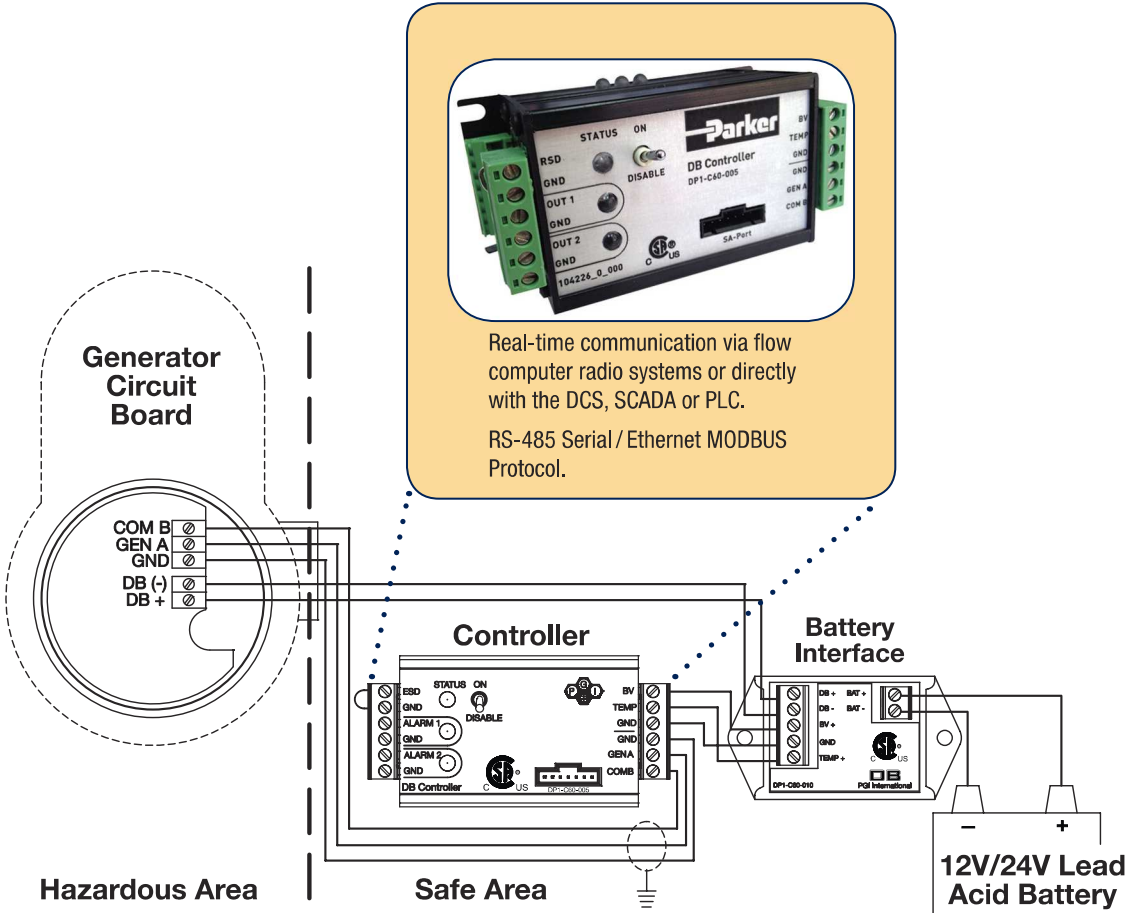

The above diagram shows the system wiring between the Generator, Controller and Battery Interface Module. The Generator and the Controller each have a micro-processor. By using separate micro-processors, the Generator can monitor itself, monitor the communications link to the Controller, and shut the Control Valve using power from the Generator (until the turbine stops) if necessary. The Generator monitors RPM, charge current, control valve operation, and output voltage while simultaneously controlling the charging process. All other parameters (battery voltage, battery temperature, remote shut-down input, alarm output, status LEDs) are monitored and managed by the Controller micro-processor. The DB1 can be monitored without removing the cover on the Generator’s explosion-proof enclosure. A battery temperature sensor, the battery interface field terminals, and over-current protection are provided in a Battery Interface Module mounted on or as close to the battery as possible.

DB1 Model Number Options

Example: DB1-20-COMVCH — 20 Watt DB1 with Optional MODBUS and Carbon Steel Mounting Kit

Model Number	Description	
DB1-10	10 Watt Differential Pressure Battery Charger	
DB1-20	20 Watt Differential Pressure Battery Charger	
DB1-50	50 Watt Differential Pressure Battery Charger	
Note: DB1 models include 1 ea. Software Interface Cable (DB1 to USB) w/DB Monitor Software (SK-DB1-003)		
	– Option Codes*	Option Description
	– COM	RS-485 Serial / Ethernet MODBUS Protocol – includes 1 ea. RS-485 cable (SK-DB1-004) and 1 ea. Ethernet cable (SK-DB1-005)
	– SVR	Severe Service - wetted parts suitable up to 8% H ₂ S and 8% CO ₂
	– VCH	Carbon Steel Remote Mount Kit for Mounting to 2" Pipe Stand
	– VSH	Stainless Steel Remote Mount Kit for Mounting to 2" Pipe Stand



The severe service option is identified by a yellow lid.

*Note: A dash appears before the first option code. If multiple options are ordered, each option code immediately follows the preceding option code; e.g., there is no dash or space between codes after the first one. See example above.

Accessories

Part Number	Description
P8-214-A0	3/4" NPT Pipe Union
P8-215-C0	1/2" 316 SS Ball Valve
SK-DB1-003	Software Interface Cable (DB1 to USB) w/DB Monitor Software (1 ea. Included with DB1 Models)

Part Number	Description
SK-DB1-004	RS-485 Cable (1 ea. Included with COM Option)
SK-DB1-005	Ethernet Cable (1 ea. Included with COM Option)
SS-C9E-500-CL	0 – 2,000 psi Gauge (316 SS, Liquid-Filled, 1/4" MNPT Center Back Mount with 2-1/2" Dial)
SS-C9E-516-CL	0 – 300 psi Gauge (316 SS, Liquid-Filled, 1/4" MNPT Center Back Mount with 2-1/2" Dial)

DB Field Installations



The DB1 is perfect for remote locations requiring power, and the communications controller allows real-time monitoring of the device. Also, the theft and vandalism associated with solar panels are not an issue with the DB1's compact, sturdy design.



Unlike solar panels, the DB1 keeps remote batteries charged in any weather condition. As shown here, a winter freeze or even an overcast day won't affect the DB1's operation.

Detailed Specifications



Compact Design
7" W x 10" D x 12" H

Detailed Specifications

Hazardous Location Classification	Class I, Division 1, Group D certified
Charger Output	12/24V (temp comp) for Lead Acid Batteries
Output Power when Charging	10, 20 or 50 Watts continuous at 68°F (20°C) ambient
Remote Battery Temperature Sensor	Silicone diode
Alarm Status & Notification	LED & NPN Open Collector (2) 30V Max, 200mA Max
Transient Protection	Bi-directional TVS 1500 Watts peak pulse power
Battery Short Circuit Protection	10 amp PTC Over Current Protection
Electrical Connections	½" NPT Rigid Conduit Opening (2) [Explosion Proof]
Wire Connections	Terminal Strip w/Screw Clamp, 14 AWG max
Communications	RS-485 Serial / Ethernet MODBUS Protocol (-COM Option)
Severe Service	Wetted parts suitable up to 8% H ₂ S and 8% CO ₂ (-SVR Option)
Inlet Gas Supply Pressure	1440 psig Maximum
Gas Flow During Charge Cycle	30 SCFM @ 10 Watts, 65 psig differential 40 SCFM @ 20 Watts, 85 psig differential 65 SCFM @ 50 Watts, 125 psig differential
Gas Supply Connections	Inlet 3/8" OD SS Tubing, Outlet 3/4" FNPT
Operating Temperature Range	-20°C (-4°F) to 40°C (104°F)
Enclosure	Cast Aluminum A356-T6, 316 SS NEMA 4X

DB1 Monitor Software

Monitor Main Menu

The screenshot shows the 'DB Monitor Version 2.0.0.0' main menu. It features a menu bar (File, View, Setup, Calibrate, Test, Help) and a toolbar with 'I.D.', 'Status', 'Configuration', and 'MODBUS' buttons. The main display area is divided into several sections:

- Battery:** Shows 13.27 Volts and 70 °F.
- Event Clock:** Shows 08:19:24 AM on 05/16/13 with 64 New Events.
- Alarm Output1/2:** Shows 'xxxx' for both.
- RSD:** Shows 'Run Enabled'.
- Charger:** Displays 'Setpoints' (Full Charge: 15.15 V, Low Battery: 12.20 V, Charge Current: 4000 mA) and 'Generator' status (Charging: 50.4 Watts, 13.74 Volts, 3670 mAmps, 2304 RPM). It also lists 'Avg Charge Time: 0:00:50', 'Avg Discharge Time: 21:52:02', 'Avg Total Cycle Time: 21:52:52', 'Total Run Time: 0:30:22', and 'Service Due In: 4,999 hours'.

 The status bar at the bottom indicates 'COM22 | Online - Retrieving MODBUS Address'.

Charger Set-Up

The 'Setup Charger' window allows configuration of the charging system. It includes:

- 12 Volt Lead Acid:** Selected with radio buttons.
- 24 Volt Lead Acid:** Unselected.
- Low Battery % of Discharge:** Set to 20% via a dropdown menu.
- Temperature:** 'Fahrenheit' is selected.
- Settings at 71°F:** Shows 'Full Charge: 15.12 V' and 'Low Battery: 12.20 V'.
- Enable RSD Input:** Checked with a checkbox.
- Buttons:** 'DB Save' and 'Exit'.

Quick View

The 'DB Gauges' window provides a visual overview of system status:

- Battery:** A horizontal gauge showing 13.27 V and 71°F.
- Charger:** Four circular gauges for Volts, Amps, Watts, and RPM. A legend indicates 'Standby' (white), 'Charging' (red), and 'Disabled' (grey).
- Exit:** A button at the bottom right.

Alarm Configurator

The 'Setup Alarms' window maps 13 major and minor alarms to two outputs:

- Major Alarms:** 6 items listed, including 'Lost Generator Communications Link', 'Control Valve is Full Open but no RPM Detected', 'Control Valve Failed', 'Generator RPM or Voltage Output Too High', 'Turbine RPM Sensor Failed', and 'Control Valve Position Sensor Failed'.
- Minor Alarms:** 7 items listed, including 'Controller Switch is in Disable Position', 'Unable to Generate Maximum Power with Control Valve Full Open', 'RSD (Remote Shut Down) Input Detected', 'Generator Run Time Service Due', 'Temperature Sensor Failed', 'Unable to Reach Full Battery Charge', and 'Modbus Shut Down'.
- Legend:** Latched alarms (7, 9, 13) also disable the generator.
- Buttons:** 'DB Save' and 'Exit'.

Event Log

The 'Event Log' window shows a list of 79 events. Summary statistics:

- Total Events: 79
- New Events: 79
- Marked as Read: 0
- Displayed: 79

 The event list table is as follows:

Count	Time Stamp (mm/dd/yy)	Battery	Event
1	05/16/13, 08:24:21 AM	13.14V	ALARM on Output2 Active
2	05/16/13, 08:24:20 AM	13.15V	Generator Stopped
3	05/16/13, 08:24:20 AM	13.15V	ON/Disable switch in DISABLE position
4	05/16/13, 08:22:04 AM	12.88V	Generator Started
5	05/16/13, 08:21:59 AM	13.16V	Power ON
6	05/16/13, 08:21:31 AM	13.02V	ALARM on Output2 Active
7	05/16/13, 08:21:30 AM	13.02V	Generator Stopped
8	05/16/13, 08:21:30 AM	13.02V	ON/Disable switch in DISABLE position
9	05/16/13, 08:20:16 AM	12.84V	Test charge current set
10	05/16/13, 08:20:16 AM	12.84V	Using Test Power Value
11	05/16/13, 08:20:09 AM	12.88V	Generator Started
12	05/16/13, 08:20:03 AM	13.16V	Power ON
13	05/16/13, 08:19:43 AM	13.08V	ALARM on Output2 Active

MODBUS Configurator

The 'MODBUS Configurator' window sets communication parameters:

- MODBUS unit address:** 1
- Protocol Mode:** RTU
- Connection Port:** RS 485 (selected), Ethernet.
- Settings:** Baud (9600), Data Bits / Protocol Mode (8 / RTU), Parity (None), Stop Bits (1).
- Buttons:** 'DB Save'.

 The status bar shows 'COM22 | Online - Retrieving Settings'.

Sales Offices Worldwide

Parker Hannifin Corporation

Instrumentation Products Division
PGI Business Unit
16101 Vallen Drive
Houston, TX 77041
USA
phone 713 466 0056
fax 713 744 9897
email pgi_sales@parker.com
www.parker.com/pgi

Parker Hannifin Corporation

Instrumentation Products Division
PGI Business Unit
18 Huashan Road, New District
Changzhou, Jiangsu
213022
China
phone +86 519 8980 7258
fax +86 519 8980 7212

Parker Hannifin Corporation

Instrumentation Products Division
PGI Business Unit
11, Fourth Chin Bee Rd
619702
Singapore
phone +65 6887 6300
fax +65 6265 5125

Sold and Serviced by:



5631 Burbank Rd SE, Calgary, AB, T2H 1Z5
Phone: 403-253-8320
info@zimco.ca / www.zimco.ca

Safety Guide – See www.parker.com/safety.

© 2016 Parker Hannifin Corporation. All rights reserved.

Bulletin PGI-DB 1/2016-DDP



Parker Hannifin Corporation
Instrumentation Products Division
PGI Business Unit
16101 Vallen Drive
Houston, Texas 77041
phone 713 466 0056
www.parker.com/pgi

Your Local Authorized Parker Distributor