



# Chemical Injection

Systems and Equipment for Oil and Natural Gas



PROVEN QUALITY. LEADING TECHNOLOGY.





# Chemical Injection Products

**“Be Green, Go Blue, Buy Graco”**

Graco chemical injection products are exactly what experienced oil and gas industry professionals want and need to meet the ongoing challenges of transferring chemicals in harsh and often remote geographies. Three words can describe it all: reliability, durability, and affordability.

## RELIABLE

- Chemical injection packages are rigorously field-tested to ensure optimum performance
- Solar pumping systems can provide reliable chemical injection for up to 4 days without sun
- Electronic injection rate controllers ensure precise injection rates – optimizing your process
- Control and monitor your chemical injection system with your mobile device for peace of mind

## DURABLE

- Pump components are designed for years of operation between service intervals
- Ideal for remote installations in extreme temperatures
- One year warranty

## AFFORDABLE

- Chemical injection equipment is available in a variety of configurations to provide premium performance at any price point
- Spend less time fixing and more time running with our durable components
- Save money by reducing chemical waste when you use our adaptive injection rate controls
- Lower energy costs by using off-the-grid solar powered systems vs. pneumatic or grid powered pumps

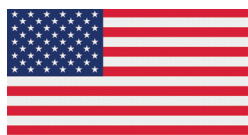

Assembled in USA



# Modular Control Box Options

When specifying the correct chemical injection system, choosing the correct control box configuration can be very critical in ensuring proper system operation. The box options below help meet all chemical injection application requirements.

## ONE-BATTERY CONTROL BOX



### One-Battery Plastic Box

Part #: B5210X

- For DC power only
- Houses a Harrier® EZ controller
- Separate tray for controller and charge controller
- Lockable box
- Comes standard with G-Chem™ solar systems



### One-Battery Metal Box

Part #: B5215X

- For DC power only
- Painted steel construction
- Lockable slide lid
- Configured for a pole mount
- Comes standard with G-Chem™ solar systems

## TWO-BATTERY CONTROL BOX



### Two-Battery Metal Box

Part #: B522XX

- For DC power only
- Houses up to two batteries
- Aluminum construction
- Lockable slide lid
- Configured for a pole mount
- Includes box and sub-plate



### Two-Battery Metal Box

Sub-Plate

- Removable sub-plate for easy battery access and ease of serviceability
- Keeps electric components and battery separate
- Sub-plates are configurable with all controller and charge controller options
- On/Off switch

## NEMA RATED CONTROL BOXES

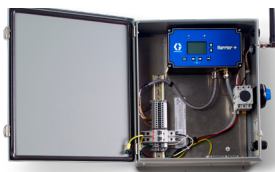

### NEMA Rated AC Box

Part #: B52AXX

- NEMA 4 rated box
- Conforms to UL-508A and CSA 22.2 No. 14 & 73
- For AC power only
- Houses the Harrier+ controller
- Painted steel construction
- Lockout/Tagout disconnect
- Configured for a pole mount



### NEMA Rated DC Box

Part #: B52NXX

- NEMA 4X rated box
- For DC power only
- Separate battery box that holds up to two batteries (Part #: B32808)
- UV resistant polycarbonate construction (UL-5VA rated)
- Lockable hinged door
- Configured for a pole mount
- Additional dual battery boxes can be linked (Part #: B32809)
- On/Off switch



## FOUR-BATTERY CONTROL BOXES



### Four-Battery Plastic Box

Part #: B32805

- For DC power only
- Houses up to four batteries
- Lockable hinged lid
- Removable sub-plate for easy battery access and ease of serviceability
- Plastic box only

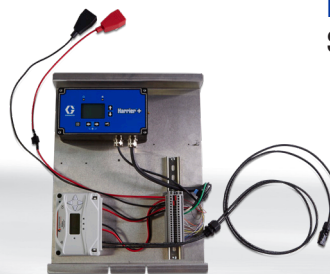

### Four-Battery Plastic Box

Sub-Plate Part #: B524XX

- Removable sub-plate for easy battery access and ease of serviceability
- Keeps electric components and battery separate
- Sub-plates are configurable with all controller and charge controller options
- On/Off switch



# Tank Level Monitoring Solution

The Graco tank level monitor and Harrier+ combination puts tank and chemical injection information at the user's fingertip, whether on-site or 1000 miles away. Not only can you monitor your chemical usage but you can also ensure proper pump operation and verification.

## How does Graco's tank level monitoring work?

The tank level sensor is a pressure transducer that connects directly into the chemical tank. The pressure is then converted to an analog signal which the Harrier+ controller correlates to a tank level. The data collected by the controller can then be tracked and manipulated via its controller portal or a connected SCADA system.

### Chemical Monitoring

Ensure your chemical tank has an adequate chemical supply with real-time monitoring of your chemical tank level.



### Flow Verification

If your chemical tank level and total pump volumes do not match up within a given threshold, the Harrier+ controller will trigger an alarm.

### Accurate

Once your chemical injection system is setup and properly calibrated, the accuracy between chemical volume in your tank and chemical pump output is within +/- 1%.

### Tank Selection Methods

Whether you have a uniform or a custom chemical tank, the Harrier+ controller can be setup to handle any shape tank.

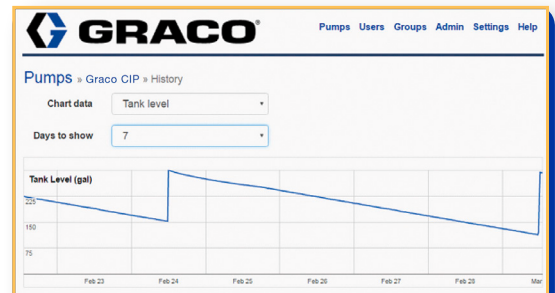
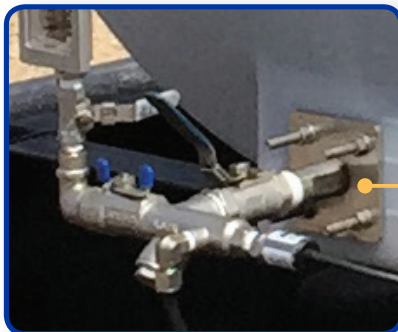

### Harrier+ Web Portal

The Harrier+ Web Portal provides 24/7 critical well site data such as local chemical inventory information for connected chemical tanks.



# Build Your Solar Chemical Injector System

## Build Your System in 4 Easy Steps!

1

### Select Your Pump

Select based on your pressure and flow requirements as well as seal material:

- Pressures: 0-10,000 psi (689 bar, 68.9 MPa)
- Flow: 0-40 gpd (151.4 lpd)
- Seal material will depend on your chemical handling requirements

2

### Configure Your Control Box

Select based on your control requirements:

- Harrier® EZ: Basic time based control
- Harrier: Time and cycle based control with auxiliary switch for DC power
- Harrier+: Adaptive flow assurance, remote pump control and automation (Class 1, Division 2 certified for Hazardous Location)
- Single, dual and multi-battery control box options
- Solar charge controllers options will be based on power consumption and required features

3

### Pick Your Solar Panel

Solar panels for General Purpose locations:

- 100W (12 VDC)
- 180W (12 VDC)
- 265W (24 VDC)

Solar panels for Hazard Locations (C1D2):

- 90W (12 VDC)
- 120W (24 VDC)
- 150W (12 VDC)

4

### Pick Your Power Stand

Select your solar panel stand based on application requirements:

- Three foot pole and stand
- Six foot pole and stand



# G-Chem™ DC and AC Operated Pumps and Systems

The G-Chem series pumps are ideal for chemical injection applications. Built from the same quality standards as current Graco chemical injection pumps, the G-Chem pump has the lowest out-of-pocket cost of Graco electric chemical injection pumps, is easy to operate and far exceed the performance of similar pumps of its class. The DC operated pumps are also offered in solar system packages that come with a 100 watt solar panel and the new Harrier® EZ controller as the standard product offering.

## Ease of serviceability

- Easy access to the pump plunger and packings
- Plunger packings can be replaced in 10 minutes or less
- Three defined stroke adjustment positions

## Harrier EZ timer

- Preset built-in low voltage disconnect
- Voltage reading and display
- Prime mode
- Built-in On/Off switch

## Robust and simple design

- Adjustable fluid packing lasts longer than non-adjustable seals
- G-Chem pumps are offered with Chromex™ coated plungers
- SST fluid section/wetted parts
- Proprietary poppet style check valve prevents valve from sticking
- Same high quality drive train used on other Graco chemical injection pumps



Harrier EZ comes standard with G-Chem Solar System

## Ordering Information

G-Chem™ DC and AC Series Pumps			
Seals / Plunger Size	1/4"	3/8"	1/2"
G-Chem Pump, 12 VDC, 1/6 hp, Simplex			
FKM	A23101	A23102	A23103
HNBR	A23107	A23108	A23109
G-Chem Pump, 12 VDC, 1/6 hp, Duplex			
FKM	A23151	A23152	A23153
HNBR	A23157	A23158	A23159
G-Chem Pump, 115 VAC, 1/6 hp, Simplex			
FKM	A23501	A23502	A23503
HNBR	A23507	A23508	A23509
G-Chem Pump, 115 VAC, 1/6 hp, Duplex			
FKM	A23551	A23552	A23553
HNBR	A23557	A23558	A23559

G-Chem™ Drive Modules			
	Simplex (50)	Duplex (55)	Duplex (h)
12 VDC	A30960	A30961	A30962
115 VAC	A30965	A30966	A30967

G-Chem™ Fluid Modules, Chromex™ Coated Plunger Rods			
Seals / Plunger Size	1/4 in	3/8 in	1/2 in
FKM	A30970	A30980	A30990
HNBR	A30971	A30981	A30991
TFE/P	A30972	A30982	A30993



# Wolverine® DC and AC Series Pumps

## Features and Benefits

Wolverine chemical injection pumps reduce emissions to the atmosphere and have a greater level of control when used with our injection rate controllers. The Wolverine Hazardous Location pumps are designed to operate in applications requiring Class 1, Division 1, rated product. These injection pumps are designed for years of operation before simple repairs. Each pump features an adjustable fluid packing that lasts up to 25 times longer than non-adjustable seals.

### Operating Environment

The Wolverine is designed to operate in environments from -40°F to 175°F (-40°C to 79°C). They have 316 SST wetted parts, plus they're sealed against water and dust.

\*Hazardous Location pumps operate at a different temperature range.

### Pump Capabilities

Flow rates up to 430 gpd (1,628 lpd) and a pressure rating up to 10,000 psi (686 bar, 68.9 MPa).

### Save Time

Easily replace pump seals in less than 5 minutes, on location.

### Accurate Control

Precision stroke adjustment between 1/4 in to 1 in (12.7 mm to 25.4 mm) ensures accurate injection rates.

### Chemical Compatibility

HNBR, FKM, FKM ETP, TFEP and FFKM plunger packings and check valve seals can handle some of the most aggressive chemicals.

### Save Power

Low friction drivetrain to optimize electrical efficiency, reducing the load on your power system.



Wolverine Chemical Injection Pumps



Wolverine Hazardous Location Pumps

## Configurations

### Fluid Plunger Sizes

- 1/8 in (3.18 mm)
- 3/16 in (4.76 mm)
- 1/4 in (6.35 mm)
- 3/8 in (9.5 mm)
- 1/2 in (12.7 mm)
- 5/8 in (15.9 mm)
- 3/4 in (19.1 mm)

### Input Power Types

- 12 VDC
- 24 VDC
- 115 VAC Single Phase
- 115/230 VAC Single Phase
- 230 VAC Single Phase
- 230/460 VAC 3-Phase

### Frequency

- Fixed Speed
- Variable Speed

### Electric Motor Sizes

- 1/11 hp (VDC)
- 1/5 hp (VDC)
- 1/4 hp (VDC)
- 1/5 hp (VAC)

### Drivetrain

- Simplex
- Duplex



Wolverine Variable Speed Pump



# Harrier® Electronic Injection Rate Controllers

## Features and Benefits

Closely control and monitor chemical use and collect critical operating information for reducing costs and improving processes. Its easy, efficient and productive – saving you time and money.

### Accurate Control

Simple user interface for setup and control. Enter your desired injection rate and let Graco do the rest!

### Remote Access

The Harrier+ controller includes remote connectivity, allowing you to monitor and control your system away from your injection site via cellular or ModBus.

### Notifications

Easily monitors your system for control, troubleshooting, maintenance needs and alerts.

### Minimize Waste

Patent pending adaptive flow control technology maintains a consistent injection rate, regardless of system variables, reducing waste and costs.

### System Control

Multiple inputs for system controls allow you to only run when it's necessary.

## Choose the model that fits your needs:

### Harrier EZ and Harrier

- Used for DC pumps
- Control injection rates via timer or cycle count
- ETL listed for electrical safety: UL 508 and CSA 22.2 No. 14
- On/Off time setting intervals from 0-999 seconds
- Built-in low voltage disconnect functionality
- Battery voltage display
- Prime mode for pump priming during setup
- Temperature display and switch for Mentanol injection

### Harrier AC

- Used with AC operated pumps
- Pump-mount and wall-mount option
- Control injection rates via timer or cycle count
- Auxiliary input port
- ETL listed for electrical safety to UL 508 and CSA 22.2 No. 14
- NEMA 4X enclosure

### Harrier+

- Used for AC and DC pumps
- Control injection rates via timer, cycle count or flow control
- Easy to read display that operates at temperatures as low as -40°F (-40°C)
- CDMA and GSM cellular connectivity
- Class 1, Division 2 certified for Hazardous Location\*



Harrier EZ Controller



AC operated Harrier mounted on a Wolverine pump

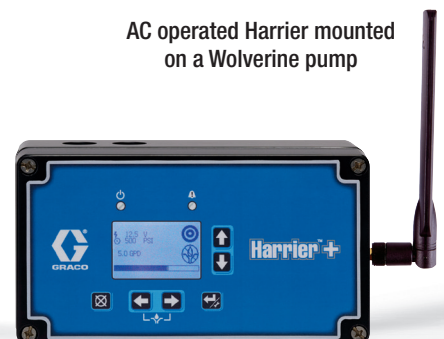

DC operated Harrier+

\*Please see certification for approval details.

# Python® Pneumatically Operated Pumps

## Features and Benefits

Python pumps are ideal for applications that require a pump to operate in an explosion proof environment and can run off regulated natural gas or compressed air. These pumps have the lowest out of pocket cost, are easy to operate and use half the air consumption of other pumps in the market. Plus, the Python's extreme duty plungers, seals and timing valve are designed for years of operation before replacement.

### Operating Environment

The Python is designed to operate in environments from -40°F to 175°F (-40°C to 79°C), made entirely from 316 SST parts and are sealed against water and dust.

### Accurate Control

Ultra precision stroke adjustment between 1/4 to 1 inch (6.4 to 25.4 mm) ensures accurate injection rates.

### Environmental

Reduced fugitive methane emissions.

### Chemical Compatibility

HNBR, FKM, FKM ETP, TFE/P, and FFKM plunger packings and check valve seals can handle some of the most aggressive chemicals.

### Consistent Operation

Pump cycle rate remains constant regardless of system back pressure.

## Configurations

### Fluid Plunger Sizes

- 1/8 in (3.18 mm)
- 3/16 in (4.76 mm)
- 1/4 in (6.35 mm)
- 3/8 in (9.5 mm)
- 1/2 in (12.7 mm)
- 5/8 in (15.9 mm)
- 3/4 in (19.1 mm)

### Air Motor Size

- 1-1/4 in (31.8 mm)
- 1-3/4 in (44.5 mm)
- 2 in (50.8 mm)

### Input Power

- Compressed air or natural gas
- Max 200 psig (13.8 bar, 1.38 MPa)

### Pump Capabilities

- Max flow rate: 165 gpd (625 lpd)
- Max pressure: 12,000 psi (827 bar, 82.7 MPa)
- Max cycle rate: 60 cycles/min

### Standards



# Python® XL Pneumatically Operated Pumps

## Features and Benefits

Python XL series pumps are ideal for wells with low gas pressure. Capable of generating up to 12,000 psi, the pumps are easy to operate and include an air motor with the same proven technology that Graco offers in other product lines. Plus the Python XL's extreme duty plungers (Chromex™ and ceramic coated), seals and air valves are designed for years of operation before replacement.

### Ease of serviceability

- Modular air valve design
- Removable pilot valve
- Pump lowers are interchangeable with other Python XL models
- Plunger packings can be replaced in 10 minutes or less

### Highest technology air motor on the market

- Only requires a minimum of 15 psi to operate pump
- Low air/gas consumption for increased efficiency
- Muffler provides low operation noise levels
- Proven Graco Merkur® air motor technology

### Robust and simple design

- 316 SST fluid section/wetted parts
- Three stroke adjustment positions
- HNBR, FKM, FKM ETP, FFKM, and TFE/P plunger packings and check valve seals

### Environmentally friendly

- 97% recoverable exhaust gas
- Reduced fugitive methane emissions

## Configurations

### Fluid Plunger Sizes

- 1/8 in (3.18 mm)
- 3/16 in (4.76 mm)
- 1/4 in (6.35 mm)
- 3/8 in (9.5 mm)
- 1/2 in (12.7 mm)
- 5/8 in (15.9 mm)
- 3/4 in (19.1 mm)

### Air Motor Size

- 2-1/2 in (63.5 mm)
- 3-1/2 in (88.9 mm)
- 4-1/2 in (114.3 mm)

### Input Power

- Compressed air or natural gas
- Min 15 psig (1.03 bar, 1.03 MPa)

### Pump Capabilities

- Max flow rate: 392 gpd (1484 lpd)
- Max pressure: 12,000 psi (827 bar, 82.7 MPa)
- Max cycle rate: 100 cycles/min

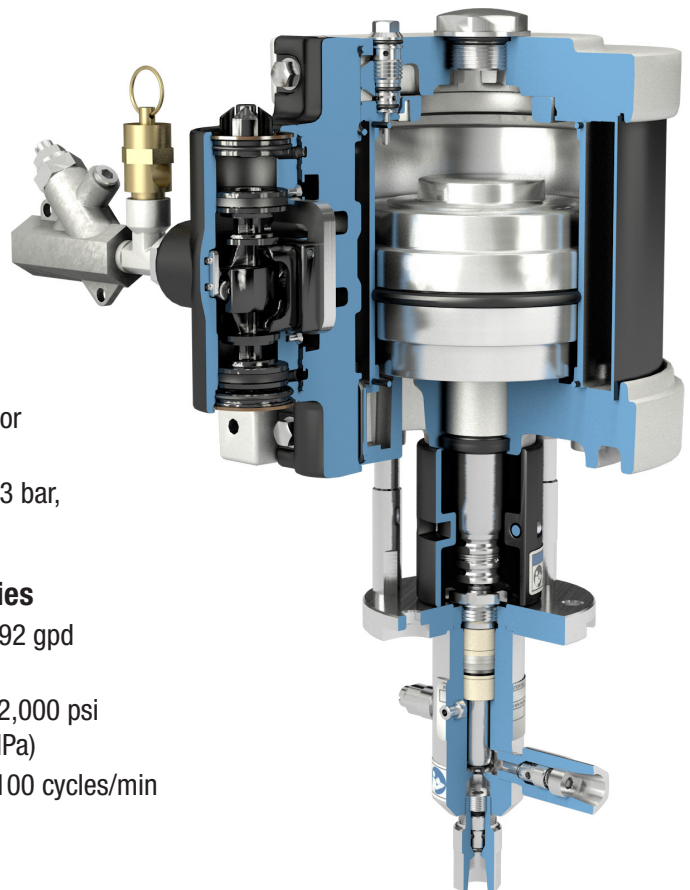



# Python® XL-DA Pneumatically Operated Pumps

## Features and Benefits

Python XL-DA series pumps are suitable for chemical injection applications that require higher flows at high pressures. These pumps operate on low gas or compressed air pressures and utilize the same Merkur® air motor used on other Graco products. The Graco patented high efficiency air valve helps minimize fugitive emissions and gas recovery can be achieved on specific models. The Python XL-DA pumps fluid in both stroke directions which provides continuous flow operation and prevents the pump from air locking.

### Double acting

- Pumps fluid in both directions of the stroke for increased flows
- Provides continuous flow operation for better pump efficiencies

### Self priming

- Anti-locking so air cannot get trapped inside air motor and stall pump
- Pump can free itself of air and resume pumping without any adjustments

### Ease of serviceability

- Simple pump design for quick seals replacement
- Pumps are installed vertically for a reduced footprint
- Minimum number of tools required

### Environmentally friendly

- Recoverable exhaust gas with kit
- Less fugitive emissions
- 4.5" air motors come ready for a gas recovery add-on kit

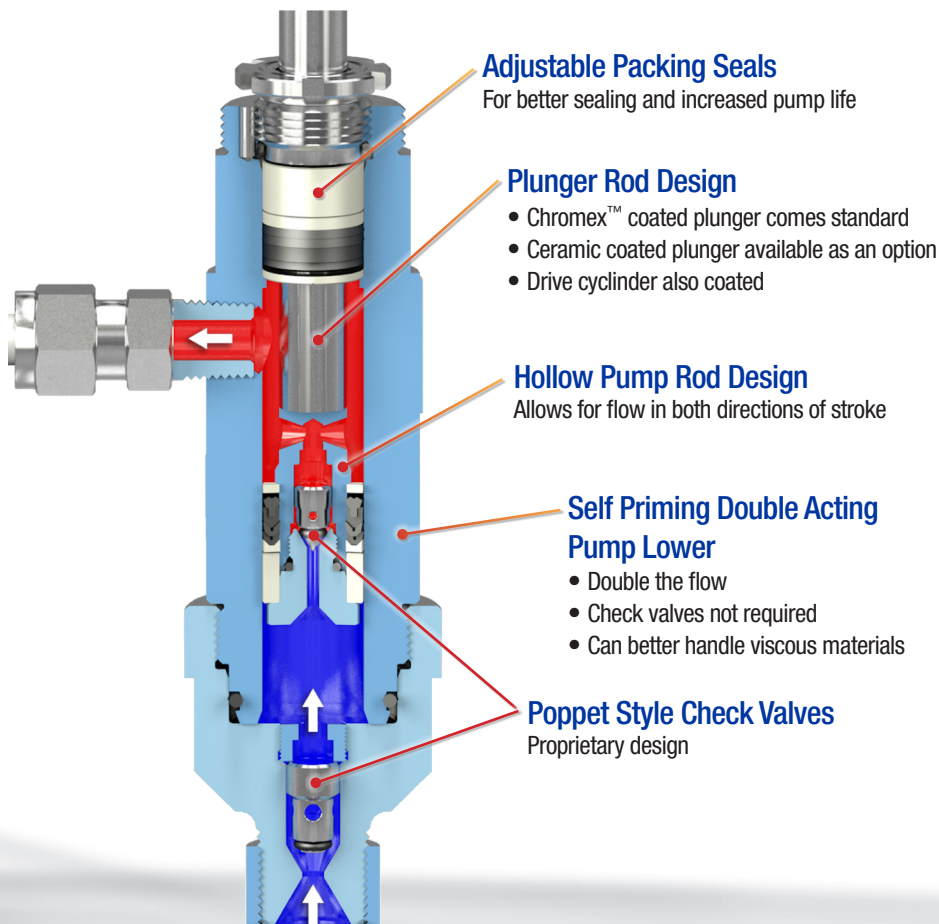

Python XL-DA 2.5"



Python XL-DA 3.5"



Python XL-DA 4.5"

# Wolverine® DA Electrically Operated Pumps

## Features and Benefits

The Wolverine DA uses a double acting pump fluid section that helps achieve double the flow of a similar single acting pump. It is also self-priming so the pump can purge itself from any trapped air and resume operation without physically being at the pump. The fluid sections are universal and can be used with pneumatic and electric drives. The Wolverine DA mounts directly on a pole, eliminating a need for a stand.

The pump uses a brushless motor which helps keep power draw at a minimum plus it comes with variable speed control right on the motor. The DC motor options are UL classified to Class 1, Division 2 for Hazardous Location applications.

### Double acting

- Pumps fluid in both directions of the stroke for increased flows
- Provides continuous flow operation for better pump efficiencies
- Doubles the flow of a similar single acting pump

### Self priming

- Anti-locking so air cannot get trapped inside air motor and stall pump
- Pump can free itself of air and resume pumping without any adjustments

### Ease of serviceability

- Simple pump design for quick seals replacement
- Pumps are installed vertically for a reduced footprint
- Pump mounts directly on a pole
- Minimum number of tools required

### Variable speed motor

- Suitable for applications requiring continuous chemical dosing
- Brushless DC motor helps reduce amperage draw
- Variable speed control eliminates a need for a separate controller



# Mongoose™ Electronic Low Pressure Chemical Metering Pump

## Features and Benefits

Our Mongoose series metering pump is suitable for dispensing chemicals for a variety of diverse markets such as oil and natural gas, mining, agriculture, landscaping and lawn maintenance, waste water, and car wash. These pumps can also be used in chemical dosing maintenance applications including cooling towers, boilers, and plating, as well as a multitude of other uses.

### Graco check valves

- Proprietary design (SST Head)
- Poppet style eliminates valve from sticking
- Same style valve used on other Graco chemical pumps

### Overload protection

- Self resetting thermal overload prevents overheating
- Over current protection
- Easily replaceable fuse for overcurrent
- No longer a throwaway pump

### Prime/air bleed port

- No need to remove fluid section to prime pump
- Quick and easy priming

### Other features

- Manual stroke adjustment
- Splash cover over controls
- NEMA 4x style enclosure
- UL and CSA certified



## Configuration Number Matrix

Check the identification plate (ID) for the 11-digit Configuration Number of your pump. Use the following matrix to define the components of your pump. *NOTE: Not all combinations are possible.*

Sample Configuration Number: **LCI-1A15-SPD-0**

LCI	1A	15	S	P	D	0					
Low Pressure Chemical Injection	Voltage	Pump Performance	Pump Material	Diaphragm Material	Check Valve Seal Material	Options					
Voltage		Pump Performance		Pump Material		Diaphragm Material		Check Valve Seal Material		Options	
12	12 VOC	10	10 gpd (37.8 lpd) 140 psi (9.6 bar)	S	316 SST	P	PTFE Coated	D	FFKM	0	None
1A	120 VAC	15	15 gpd (56.7 lpd) 150 psi (10.3 bar)	K	PVDF			A	FKM	1	Ball/Seat
2A	240 VAC	17	17 gpd (64.3 lpd) 250 psi (17.2 bar)								
		30	30 gpd (113.5 lpd) 110 psi (7.5 bar)								
		45	45 gpd (170.3 lpd) 75 psi (5.2 bar)								



# G-Chem™ Beam Pump

## Features and Benefits

The G-Chem Beam Pump provides reliable and robust means of injecting chemicals for operation with a pumpjack. The G-Chem is a positive displacement plunger type pump powered by a direct connection with a cable or rod to the pumpjack's walking beam.

The G-Chem Beam Pump offering includes:

- Three preset stroke positions
- Unique actuator design with a hex shape connection allowing for additional handle positions for more accurate dosing
- Stainless steel heads for withstanding the harshest applications
- Common repair pairs are shared with the G-Chem electric pump, such as packings, plungers, check valves and fluid heads.

### Maximum performance

- Maximum flow rates up to 20 gallons per day
- Stroke adjustment range from 1/2" to 1"
- Maximum discharge pressure of 2,500 PSI

### Robust and simple design

- Graco's Chromex™ coated plunger rods
- Graco's poppet style check valves
- FKM, HNBR and TFE/P seals
- Interchangeable fluid heads with G-Chem electric series pumps





## ABOUT GRACO

### PROVEN QUALITY. LEADING TECHNOLOGY.

Founded in 1926, Graco is a world leader in fluid handling systems and components. Graco products move, measure, control, dispense and apply a wide range of fluids and viscous materials used in vehicle lubrication, commercial and industrial settings.

The company's success is based on its unwavering commitment to technical excellence, world-class manufacturing and unparalleled customer service. Working closely with qualified distributors, Graco offers systems, products and technology that set the quality standard in a wide range of fluid handling solutions. Graco provides equipment for spray finishing, protective coating, paint circulation, lubrication, and dispensing sealants and adhesives, along with power application equipment for the contractor industry. Graco's ongoing investment in fluid management and control will continue to provide innovative solutions to a diverse global market.

## GRACO LOCATIONS

### MAILING ADDRESS

P.O. Box 1441  
Minneapolis, MN 55440-1441  
Tel: 612-623-6000  
Fax: 612-623-6777

### AMERICAS

#### MINNESOTA

Worldwide Headquarters  
Graco Inc.  
88-11th Avenue N.E.  
Minneapolis, MN 55413

### EUROPE

#### BELGIUM

European Headquarters  
Graco N.V.  
Industrieterrein-Oude Bunders  
Slakweidestraat 31  
3630 Maasmechelen,  
Belgium  
Tel: 32 89 770 700  
Fax: 32 89 770 777

### ASIA PACIFIC

#### AUSTRALIA

Graco Australia Pty Ltd.  
Suite 17, 2 Enterprise Drive  
Bundoora, Victoria 3083  
Australia  
Tel: 61 3 9468 8500  
Fax: 61 3 9468 8599

#### CHINA

Graco Hong Kong Ltd.  
Shanghai Representative Office  
Building 7  
1029 Zhongshan Road South  
Huangpu District  
Shanghai 200011  
The People's Republic of China  
Tel: 86 21 649 50088  
Fax: 86 21 649 50077

### INDIA

Graco India Pvt Ltd  
Plot No 295, Udyog Vihar Phase-IV  
Gurugram - 122015 (Haryana)  
India  
Tel: 91 124 661 0200  
Fax: 91 124 661 0201

### JAPAN

Graco K.K.  
1-27-12 Hayabuchi  
Tsuzuki-ku  
Yokohama City, Japan 2240025  
Tel: 81 45 593 7300  
Fax: 81 45 593 7301

### KOREA

Graco Korea Inc.  
38, Samsung 1-ro 1-gil  
Hwaseong-si, Gyeonggi-do,  
18449  
Republic of Korea  
Tel: 82 31 8015 0961  
Fax: 82 31 613 9801

## SALES/ DISTRIBUTION/ SERVICE

Call today for product information or to request a demonstration.

**866-552-1868**, email [oilandgas@graco.com](mailto:oilandgas@graco.com) or visit us at [www.graco.com](http://www.graco.com).

Graco Inc. is registered to I.S. EN ISO 9001

North America  
Customer Service  
866-552-1868  
Fax 877-340-6427



### Zimco Instrumentation Inc.

11141 15 Street NE, Calgary, AB, T3K 0Z5 Canada

Phone: 403-253-8320

Email: [info@zimco.ca](mailto:info@zimco.ca)

Website: [www.zimco.ca](http://www.zimco.ca)